

INDUSTRIAL ROBOTS

SCARA ROBOTS

General catalog for SCARA robots

THL Series

THL Series



Wide-ranging and diverse industrial robots contribute to automation, labor saving and increased efficiency.

Since it was founded in 1938 the Shibaura Machine group has played a role in helping Japan and the development of manufacturing worldwide by supplying the machines that were required by industry. The brand name "Shibaura" is widely recognized in the machine tool industry. The expertise in advanced machine design, manufacturing and control technology, which has been developed by our machine tool division, has been applied to our SCARA robot. Shibaura Machine started selling SCARA robots in the 1980s, and the customer benefits from our extensive development experience.

Shibaura Machine continues to offer increasing value for the customer with our industrial machine manufacturing, including the SCARA robot, epitomizing our corporate message: "View the future with you."

SHIBAURA MAC

	TOSHIBA CORPORATION			Toshiba Machine Co., Ltd.													
SCARA Robot	'81 Development of the SCARA robot			SR-424HSP	TH250	TH350	Model change			TH180	TH250A	TH350A					
	'83 SR-H Series	'87 SR-HS Series	'92 SR-HSP Series	SR-554HSP	Model change			TH450	TH550	Model change							
			'91 SR-1054HZ (Heavy payload SCARA robot)	SR-1504HZ (Heavy payload SCARA robot)	TH650	TH850	TH1050	Model change			TH650A	TH850A	TH1050A				
	1980	1985	1990 '95	1996	2000	2001	2002	2003	2004	2005	2006	2007	2008				
Vertical Articulated Robots and others SCARA Robot	SR-606V (Vertical articulated robot)	SR-2604V (Palletizer)	'93 Valibo (Robot for final manufacturing process)	SR-2006V (Vertical articulated robot)	SR-1806V, SR-2206V (Vertical articulated robot)	THP Series (Cartesian coordinate system)	SR-875VP	SR-875VPN	DPD	TCR20V	TCR5L	TCR20V2	TCR10L	TCR12C	TCR20C	Vertical articulated robot	TV800/TV1000
				SR-2006V (Vertical articulated robot)	SR-1806V, SR-2206V (Vertical articulated robot)	THP Series (Cartesian coordinate system)	SR-875VP	SR-875VPN	Semiconductor	SR-624HC (Cassette Transfer)	SR-F9GL3 (FOUP TRANSFER)	SR-404HC (Cassette Transfer)	SR-354VH (Cassette Transfer)	TVP1100	THC700 (SCARA Painting)		

SCARA



HIGH QUALITY

HISTORY

SHIBAURA MACHINE CO., LTD.

<ul style="list-style-type: none"> TH450A TH550A THP550 	<ul style="list-style-type: none"> THL300 THL400 	<ul style="list-style-type: none"> THL500 THL600 THL700 	<ul style="list-style-type: none"> THL800 THL900 THL1000 	<ul style="list-style-type: none"> THE400 	<ul style="list-style-type: none"> THE600 	<ul style="list-style-type: none"> THE800 THE1000 						
<ul style="list-style-type: none"> TH1200A 	<ul style="list-style-type: none"> THP700 			<ul style="list-style-type: none"> THL1200 								
2009	2010	2011	2012	2013	2014	2015	2016	2017	2018	2019	2020	2022
<ul style="list-style-type: none"> TV1000H-WP 				<ul style="list-style-type: none"> TV600 	<ul style="list-style-type: none"> TVL500 TVL700 			<ul style="list-style-type: none"> TVM900 TVM1200 TVM1500 				
			<ul style="list-style-type: none"> TLD1100 (Line Dancer) 			<ul style="list-style-type: none"> SWAN CoSWAN 						<ul style="list-style-type: none"> SR-405HC

Contributes to productivity improvement in line work by high speed operation

Maximum payload mass

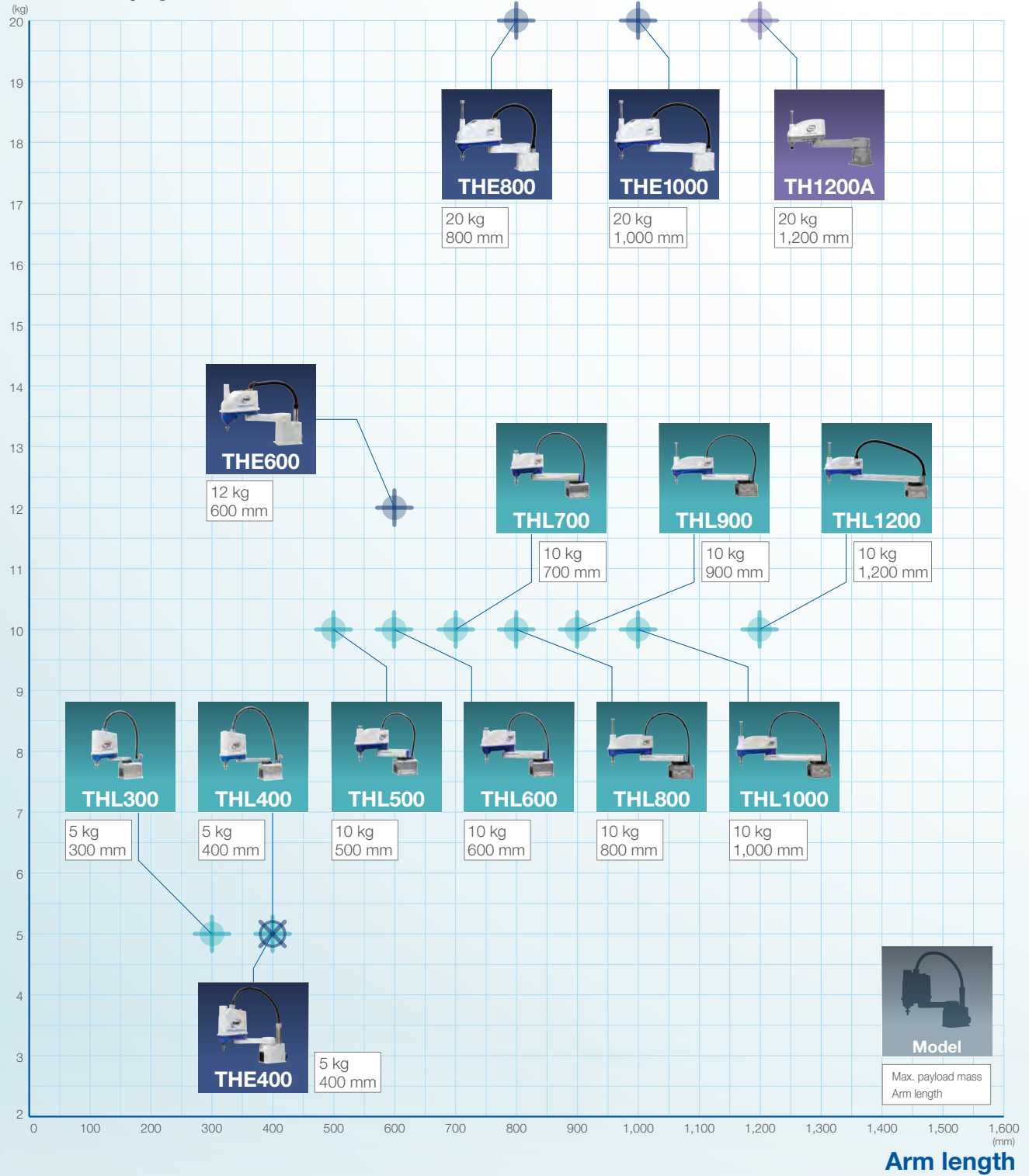

Various options

(Main robot options)

- Z-Axis long stroke
- Protective bellows for Z-Axis
- Z-Axis cap
- Cleanroom specification
- Dust-proof and splash-proof specification
- Ceiling-mount type
- Tool flange for end effector mounting
- Support of Safety Category 3
- Additional Axis (Traverse axis, Wrist axis, etc.)

Details:

THE Series: P13

THL Series: P25

and high performance handling. Selection can be made according to the application.

Standard cycle time

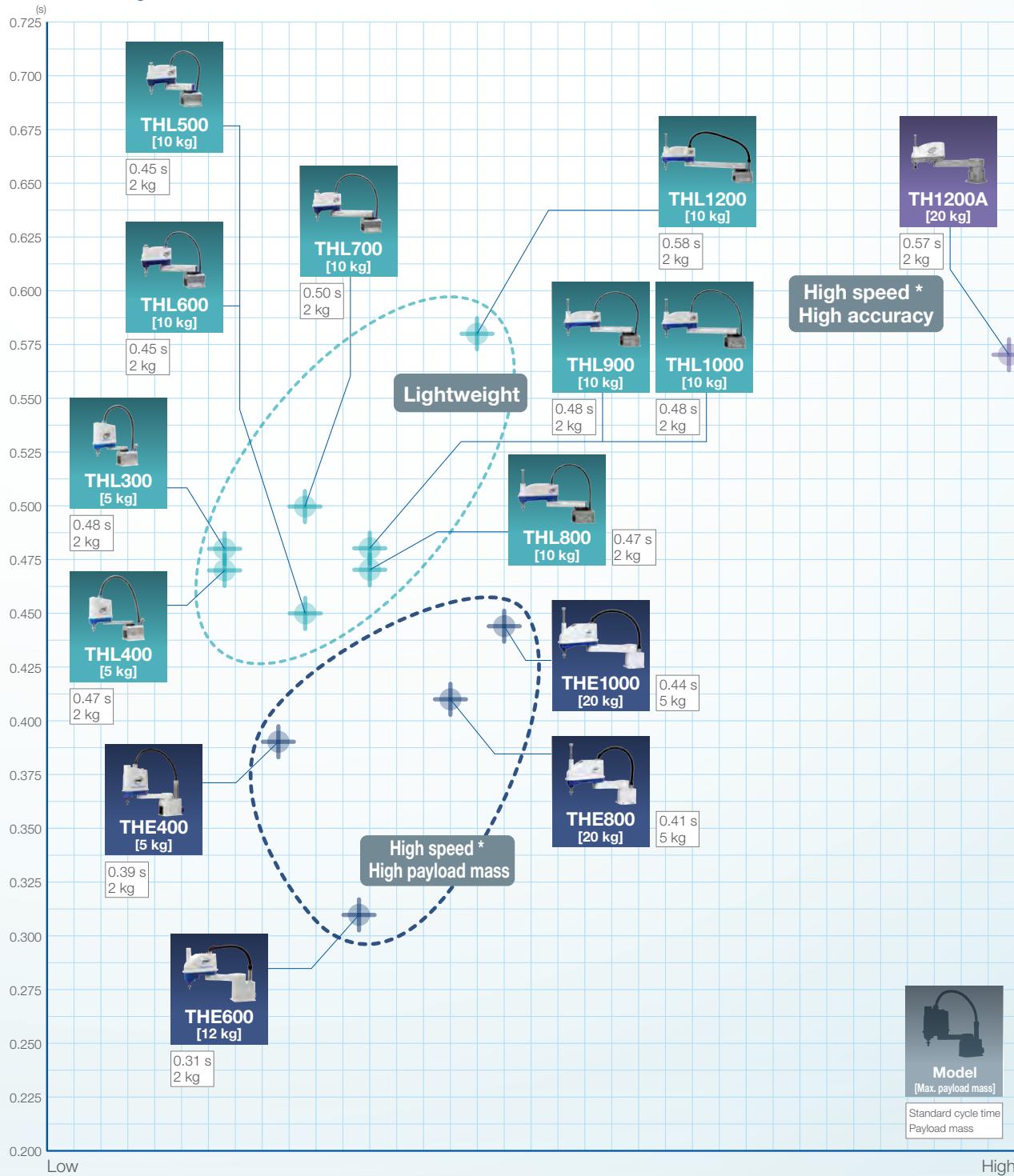

Price range



Please watch the videos of our SCARA robot

To see this application video use this QR code or see the details below

<https://www.youtube.com/watch?v=f7o5qgcEI7I>



To download the catalog and CAD data use this QR code or see the details below

<https://www.shibaura-machine.co.jp/en/product/robot/download.html>



Example of applications using SCARA robots

Type: THL

Conveyance and Inspection of battery cells

The battery cell is transported at high speed to the inspection equipment and can be easily transported even when it is heavy.



To see the application video use this QR Code

<https://www.youtube.com/watch?v=wBW0KPy3nPc>



Type: THE

Conveyance of cosmetic items with conveyor tracking

Synchronization with the conveyor enables robots to sort and convey efficiently.

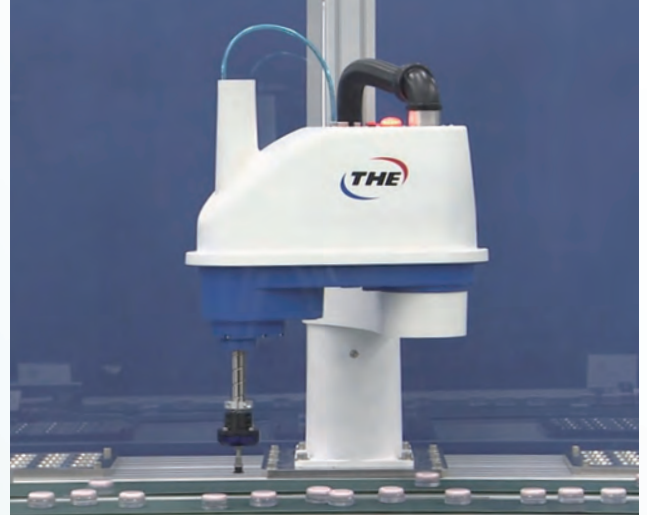

To see the application video use this QR Code

<https://youtu.be/f7o5qgcEI7I>



Type: THL

Bolt fastening and conveyance of small parts

Assembly of small parts, fastening of bolts and conveying of completed parts.



To see the application video use this QR Code

<https://youtu.be/N4tbGTLEBcl>



Type: THL

Robot system for high torque fastening

Implementing automation of screw and nut fastening, which requires high torque fastening. It can also be used for socket changes.

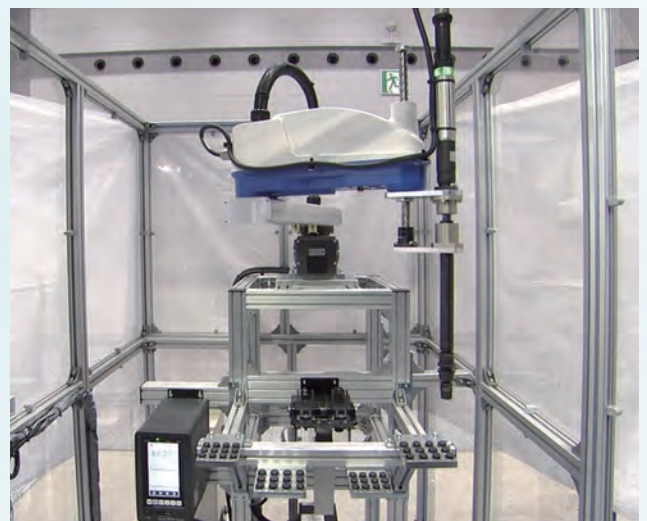

To see the application video use this QR Code

<https://www.youtube.com/watch?v=0wcvouJxEGl>



THE Series

High speed

Fastest cycle time : 0.31 sec
Support of mass production for precision parts

High accuracy

Suitable for the assembly and the inspection process of electronics equipment and automobile components, where precision is required

Accurate movement trajectory

Suitable for coating process for grease and adhesive



Order
model
code

THE 400 - Z - B - L05 - TF - E - S

Arm length

Z-Axis long stroke

Tool flange for end effector mounting

E: CE Marking
K: KCs Marking

BL: Battery-less type motor
S: Special specification

Cable between robot and controller

Cable between robot and controller L05: Cable length 5 m, L08: Cable length 8 m, L10: Cable length 10 m, L15: Cable length 15 m, L00R: Cable length 3.5 m (movable), L05R: Cable length 5 m (movable), L08R: Cable length 8 m (movable), L10R: Cable length 10 m (movable), L15R: Cable length 15 m (movable)

Option B: Z With protective bellows, C: With cap, CRB: Clean room design, WS: Z-axis (axis3) shaft for wire routing, IP: IP65 dust-proof and drip-proof, T: Ceiling-mount type, WB: Z-axis (axis 3) upper and lower bellows



THE400



THE600



THE800



THE1000

Model	THE400	THE600
Arm length (1st Arm + 2nd Arm)	400 mm (225 mm+175 mm)	600 mm (325 mm+275 mm)
Maximum speed (Axis 1 and 2 composite)	7000 mm/sec	8000 mm/s
Standard cycle time (with 2 kg load) ¹	0.39 sec	0.31s
Maximum payload mass ²	5 kg (rated 1 kg)	12 kg (rated 2 kg)
Positioning repeatability ³		
X-Y	±0.01 mm	±0.01 mm
Axis Z (Axis 3)	±0.01 mm	±0.01 mm
Axis C (Axis 4)	±0.007 deg	±0.005 deg
Mass	15 kg	31 kg
Connectable controller	TSL3000, TSL3000E, TS5000-SS, TS5000-EMS	TS5000-MS, TS5000-EMS
Model	THE800	THE1000
Arm length (1st Arm + 2nd Arm)	800 mm (350 mm+450 mm)	1000 mm (550 mm+450mm)
Maximum speed (Axis 1 and 2 composite)	8400 mm/sec	9500 mm/sec
Standard cycle time (with 2 kg load) ¹	0.41 sec	0.44 sec
Maximum payload mass ²	20 kg (rated 5 kg)	20 kg (rated 5 kg)
Positioning repeatability ³		
X-Y	±0.025 mm	±0.025 mm
Axis Z (Axis 3)	±0.01 mm	±0.01 mm
Axis C (Axis 4)	±0.01 deg	±0.01 deg
Mass	46 kg	49 kg
Connectable controller	TS5000-MS	TS5000-MS

¹1: Continuous operation is not possible beyond the effective load ratio. Horizontal 300 mm, vertical 25 mm, round-trip with coarse positioning.

²2: Acceleration/deceleration rates and maximum speed may be limited according to the motion pattern, load mass and amount of offset.

³3: Positioning repeatability accuracy in one-direction movement, when the environmental temperature and robot temperature are constant. It is not the absolute positioning accuracy. The specification value may be exceeded depending on moving pattern, load mass and offset amount. Positioning repeatability for X-Y and C are for when Z-axis is at the uppermost position. Trajectory accuracy is not ensured.

THE400



Model	THE400	
Arm length (1st Arm + 2nd Arm)	400 mm (225 mm+175 mm)	
Working envelope	Axis 1	±130 deg
	Axis 2	±145 deg
	Axis 3 (Axis Z)	0~160 mm
	Axis 4 (Axis C)	±360 deg
Maximum speed	Axis 1	672 deg/sec
	Axis 2	780 deg/sec
	Axis 3 (Axis Z)	1120 mm/sec
	Axis 4 (Axis C)	1800 deg/sec
	Composite (Axis 1 and 2 composite)	7000 mm/sec
Standard cycle time ^{*1}	0.39 sec (with 2 kg load)	
Maximum payload mass ^{*2}	5 kg (rated 1 kg)	
Allowable moment of inertia ^{*2}	0.06 kg·m ²	
Positioning repeatability ^{*3}	X-Y	±0.01 mm
	Axis Z (Axis 3)	±0.01 mm
	Axis C (Axis 4)	±0.007 deg
Hand wiring	8 inputs and 8 outputs	
Hand pneumatic joint	Provided by user	
Robot controller cable	3.5 m	
Power supply	2.6 KVA	
Mass	15 kg	
Connectable controller	TSL3000, TSL3000E, TS5000-SS, TS5000-EMS	

For *1 to *3, please see page 8.

External View

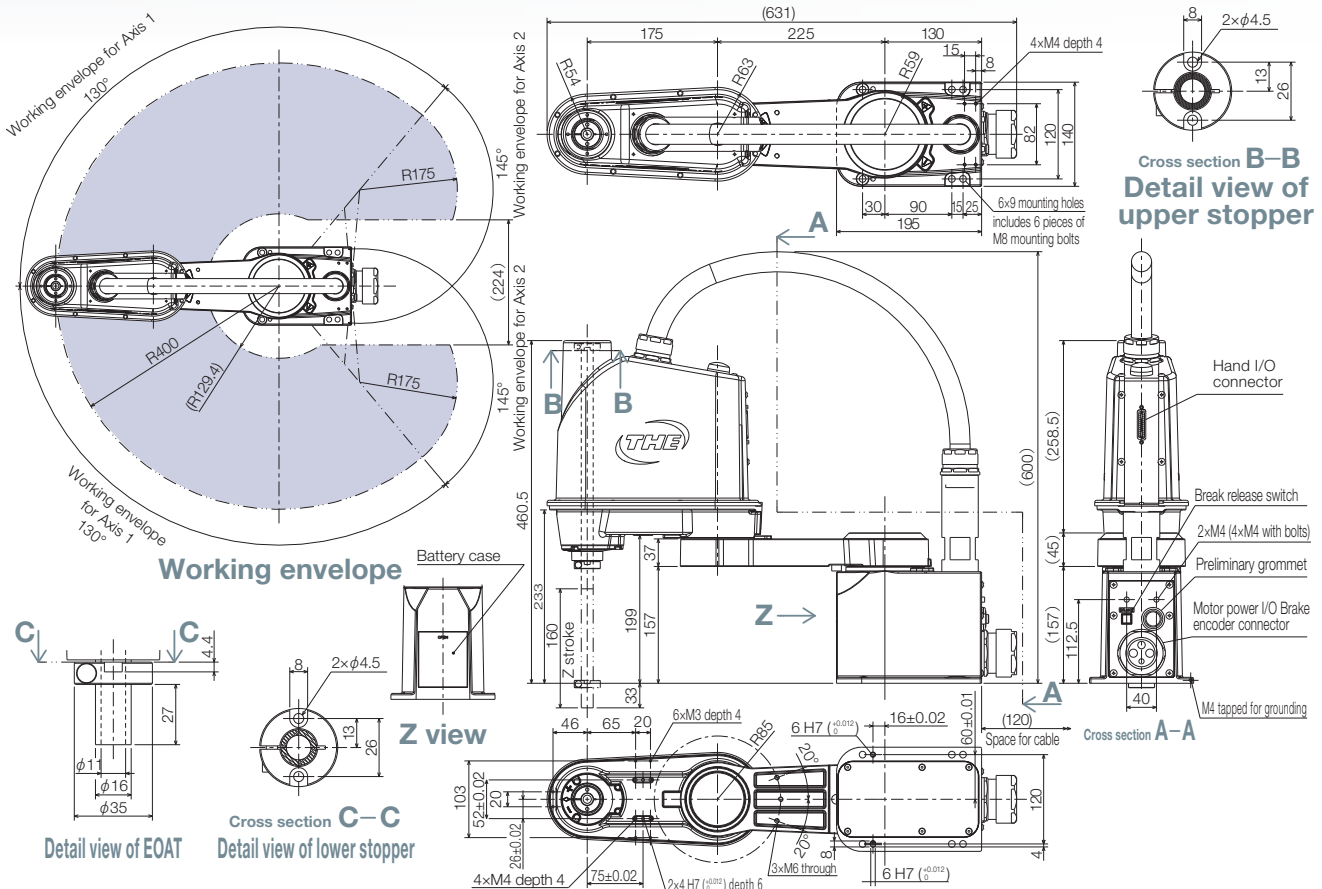

CAD Download URL <https://www.shibaura-machine.co.jp/en/product/robot/download.html>



THE600



Model		THE600
Arm length (1st Arm + 2nd Arm)		600 mm (325 mm+275 mm)
Working envelope	Axis 1	±140 deg
	Axis 2	±152 deg
	Axis 3 (Axis Z)	0~210 mm
	Axis 4 (Axis C)	±360 deg
Maximum speed	Axis 1	457 deg/sec
	Axis 2	672 deg/sec
	Axis 3 (Axis Z)	2000 mm/sec
	Axis 4 (Axis C)	2359 deg/sec
	Composite (Axis 1 and 2 composite)	8000 mm/sec
Standard cycle time ^{*1}		0.31 sec (with 2 kg load)
Maximum payload mass ^{*2}		12 kg (rated 2 kg)
Allowable moment of inertia ^{*2}		0.25 kg·m ²
Positioning repeatability ^{*3}	X-Y	±0.01 mm
	Axis Z (Axis 3)	±0.01 mm
	Axis C (Axis 4)	±0.005 deg
Hand wiring		8 inputs and 8 outputs
Hand pneumatic joint		φ6 x 4 pcs
Robot controller cable		3.5 m
Power supply		4.3 kVA
Mass		31 kg
Connectable controller		TS5000-MS, TS5000-EMS

For *1 to *3, please see page 8.

External View

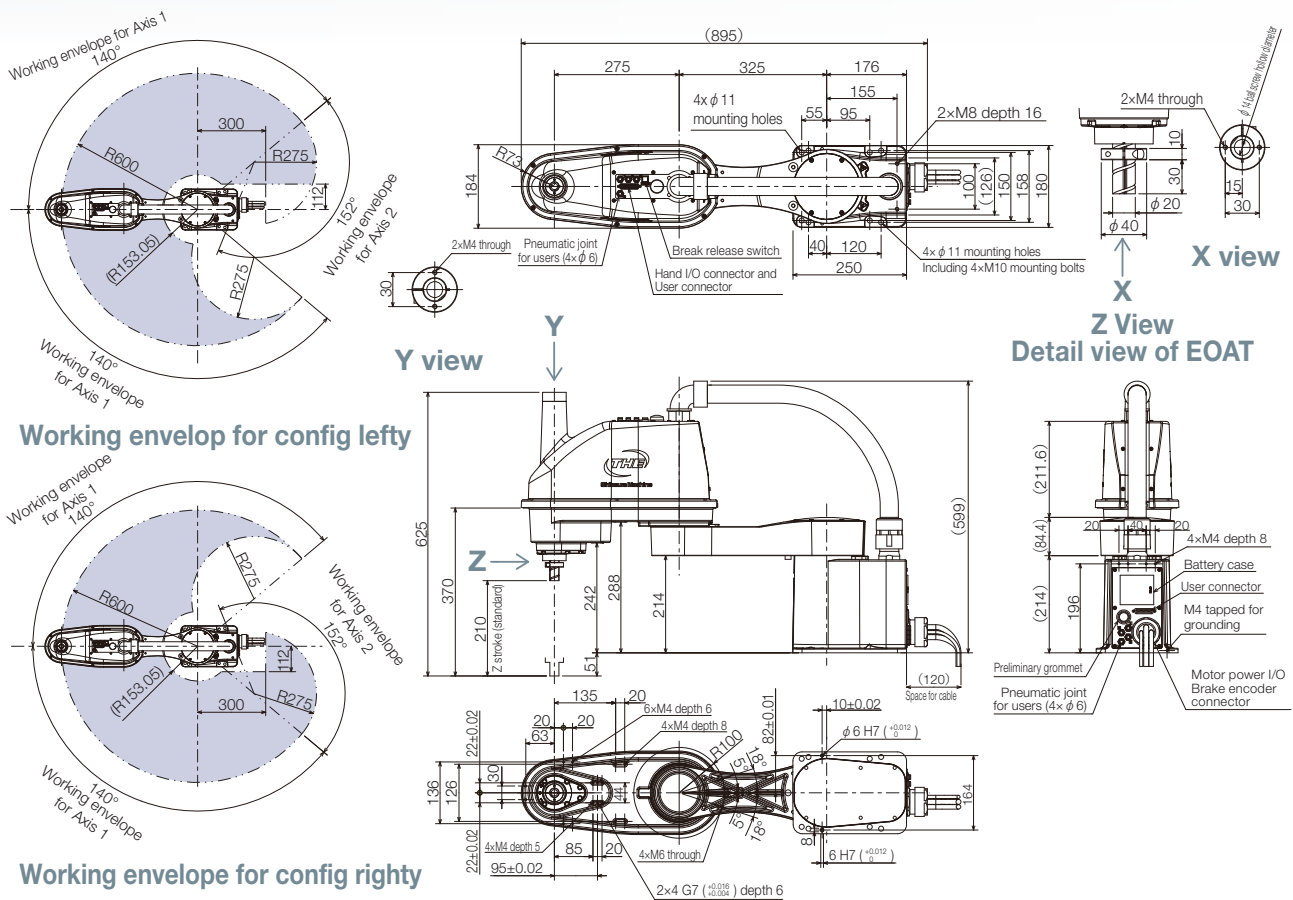

CAD Download URL <https://www.shibaura-machine.co.jp/en/product/robot/download.html>



THE800



Model	THE800	
Arm length (1st Arm + 2nd Arm)	800 mm (350 mm+450 mm)	
Working envelope	Axis 1	±132 deg
	Axis 2	±152 deg
	Axis 3 (Axis Z)	0~420 mm
	Axis 4 (Axis C)	±360 deg
Maximum speed	Axis 1	300 deg/sec
	Axis 2	540 deg/sec
	Axis 3 (Axis Z)	2200 mm/sec
	Axis 4 (Axis C)	1100 deg/sec
	Composite (Axis 1 and 2 composite)	8400 mm/sec
Standard cycle time ¹⁾	0.41 sec (with 2 kg load)	
Maximum payload mass ²⁾	20kg (rated 5 kg)	
Allowable moment of inertia ²⁾	0.6kg m ²	
Positioning repeatability ³⁾	X-Y	±0.025 mm
	Axis Z (Axis 3)	±0.01 mm
	Axis C (Axis 4)	±0.01 deg
Hand wiring	8 inputs and 8 outputs	
Hand pneumatic joint	φ6 x 2 pcs φ8 x 2 pcs	
Robot controller cable	3.5 m	
Power supply	4.3 kVA	
Mass	46 kg	
Connectable controller	TS5000-MS	

For ¹⁾ to ³⁾, please see page 8.

External View

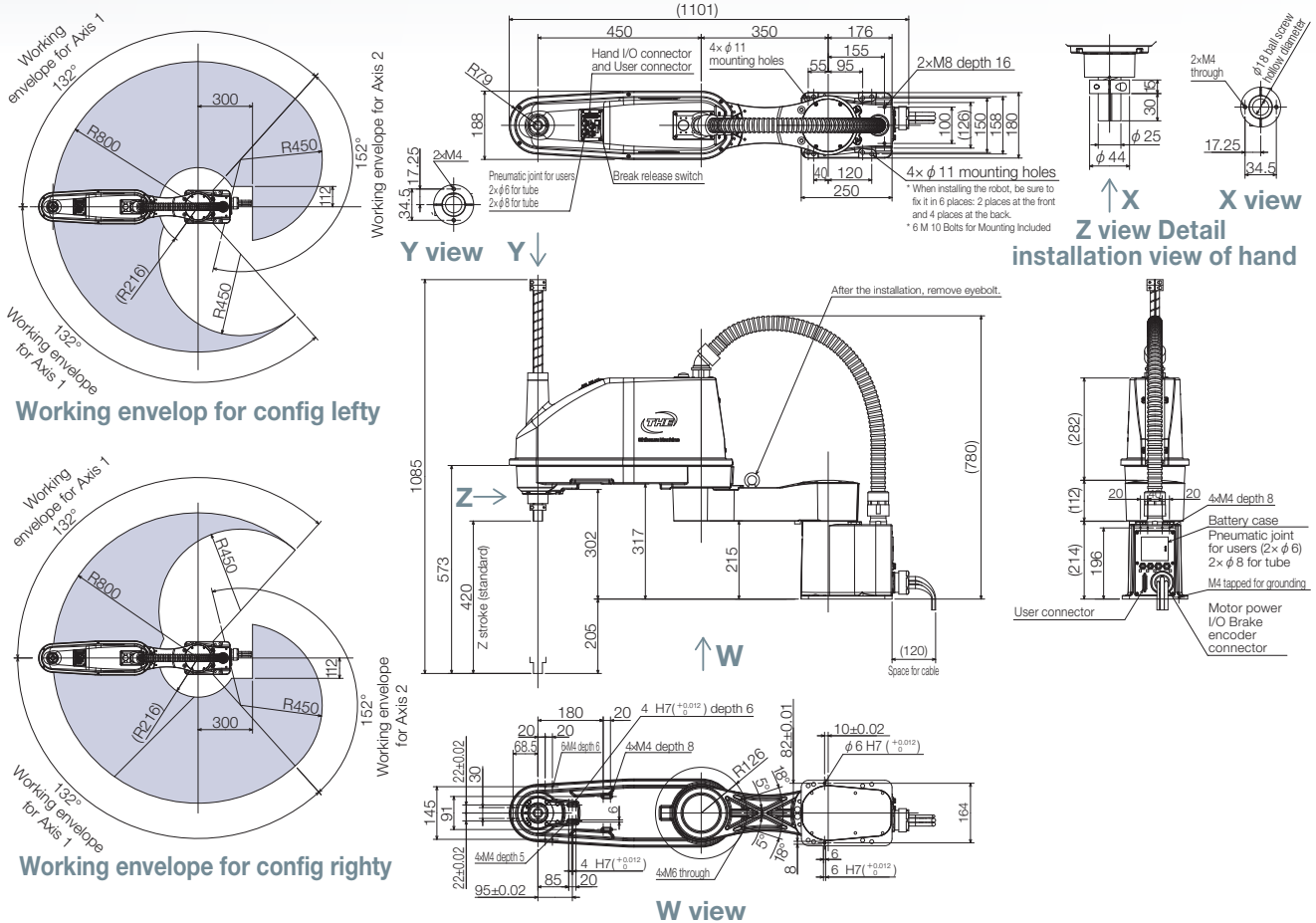

CAD Download URL https://www.shibaura-machine.co.jp/en/product/robot/lineup/th/THE800_1000.html



THE1000



Model	THE1000	
Arm length (1st Arm + 2nd Arm)	1000 mm (550 mm+450 mm)	
Working envelope	Axis 1	±132 deg
	Axis 2	±152 deg
	Axis 3 (Axis Z)	0~420 mm
	Axis 4 (Axis C)	±360 deg
Maximum speed	Axis 1	300 deg/sec
	Axis 2	540 deg/sec
	Axis 3 (Axis Z)	2200 mm/sec
	Axis 4 (Axis C)	1100 deg/sec
	Composite (Axis 1 and 2 composite)	9500 mm/sec
Standard cycle time ^{*1}	0.44 sec (with 2 kg load)	
Maximum payload mass ^{*2}	20 kg (rated 5 kg)	
Allowable moment of inertia ^{*2}	0.6 kg·m ²	
Positioning repeatability ^{*3}	X-Y	±0.025 mm
	Axis Z (Axis 3)	±0.01 mm
	Axis C (Axis 4)	±0.01 deg
Hand wiring	8 inputs and 8 outputs	
Hand pneumatic joint	φ6 x 2 pcs φ8 x 2 pcs	
Robot controller cable	3.5 m	
Power supply	4.3 kVA	
Mass	49 kg	
Connectable controller	TS5000-MS	

For *1 to *3, please see page 8.

External View

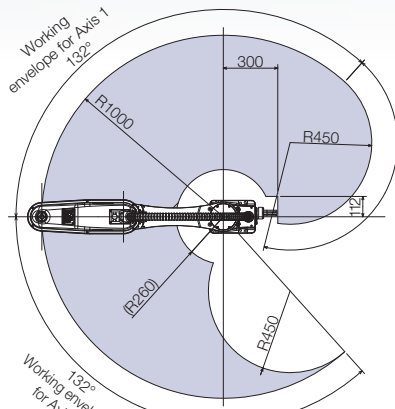

Working envelope for config lefty

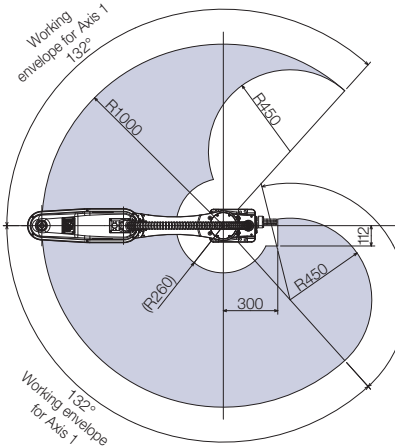

Working envelope for config righty

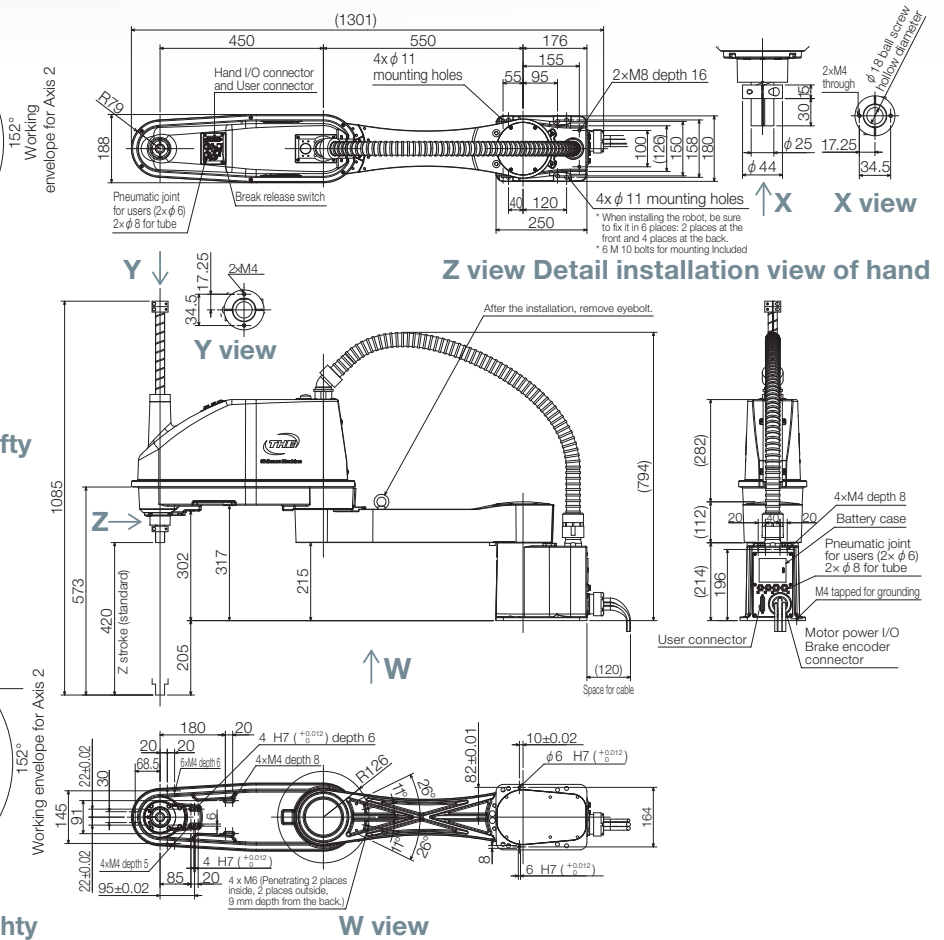

CAD Download URL https://www.shibaura-machine.co.jp/en/product/robot/lineup/th/THE800_1000.html



There are various options so that robots can be used in a variety of applications, environment, and layouts.

Z-Axis long stroke (Z)

The Z-axis stroke range is extended. Useful when handling long work pieces and when height or depth is required.

Protective bellows for Z-Axis (B)

Bellows protect the lower part of the ball screw when liquid or particles could become attached.

*Cycle time and working envelope of Z-axis (axis 3) is different from standard specification. Please contact us for more details.

Z-axis upper cap (C)

Cap protects the upper part of the ball screw when liquid or particles could become attached. It also prevents the cable from touching peripheral equipment.

Cleanroom specification (CRB)

Cleanroom design equivalent to ISO clean Class 3. Effective for dust-averse applications such as semiconductor and electronics manufacturing.

Z-axis shaft for wire routing (WS)

Adds shaft for hand wire routing. Prevents wire from scraping when the robot hand wiring is put through the hollow part of ball screw.

Dust-proof and splash-proof specification (IP)

Dust-proof and splash-proof specification equivalent to IP65. (Does not allow dust intrusion and prevents the robot from the harmful effects of splashing water.)

*Limitation of acceleration/deceleration rates. Please contact us for more details.

Order model code

EX. THE 400 - Z - B - L05 - TF - E - S

● Arm length	● No.1	● No.2	● No.3	● No.4	● No.6																																																		
400~1000	<table border="1"> <tr><td>No symbol</td><td>No option (standard)</td></tr> <tr><td>Z</td><td>Z-Axis long stroke (Z)</td></tr> </table>	No symbol	No option (standard)	Z	Z-Axis long stroke (Z)	<table border="1"> <tr><td>No symbol</td><td>No option (standard)</td></tr> <tr><td>B</td><td>Protective bellows for Z-Axis</td></tr> <tr><td>C</td><td>Z-axis upper cap (C)</td></tr> <tr><td>CRB</td><td>Cleanroom specification</td></tr> <tr><td>WS</td><td>Z-axis (axis3) shaft for wire routing</td></tr> <tr><td>IP</td><td>Dust-proof and splash-proof specification (IP65)</td></tr> <tr><td>T</td><td>Ceiling-mount type</td></tr> <tr><td>WB</td><td>Z-axis (axis 3) upper and lower bellows</td></tr> </table>	No symbol	No option (standard)	B	Protective bellows for Z-Axis	C	Z-axis upper cap (C)	CRB	Cleanroom specification	WS	Z-axis (axis3) shaft for wire routing	IP	Dust-proof and splash-proof specification (IP65)	T	Ceiling-mount type	WB	Z-axis (axis 3) upper and lower bellows	<table border="1"> <tr><td>No symbol</td><td>Cable length 3.5 m (standard)</td></tr> <tr><td>L05</td><td>Cable length 5 m</td></tr> <tr><td>L08</td><td>Cable length 8 m</td></tr> <tr><td>L10</td><td>Cable length 10 m</td></tr> <tr><td>L15</td><td>Cable length 15 m</td></tr> <tr><td>L00R</td><td>Cable length 3.5 m (movable)</td></tr> <tr><td>L05R</td><td>Cable length 5 m (movable)</td></tr> <tr><td>L08R</td><td>Cable length 8 m (movable)</td></tr> <tr><td>L10R</td><td>Cable length 10 m (movable)</td></tr> <tr><td>L15R</td><td>Cable length 15 m (movable)</td></tr> </table>	No symbol	Cable length 3.5 m (standard)	L05	Cable length 5 m	L08	Cable length 8 m	L10	Cable length 10 m	L15	Cable length 15 m	L00R	Cable length 3.5 m (movable)	L05R	Cable length 5 m (movable)	L08R	Cable length 8 m (movable)	L10R	Cable length 10 m (movable)	L15R	Cable length 15 m (movable)	<table border="1"> <tr><td>No symbol</td><td>Tool flange for end effector mounting (standard)</td></tr> <tr><td>TF</td><td>Tool flange for end effector mounting</td></tr> </table>	No symbol	Tool flange for end effector mounting (standard)	TF	Tool flange for end effector mounting	<table border="1"> <tr><td>No symbol</td><td>No other options (standard)</td></tr> <tr><td>BL</td><td>Battery-less motor (BL)</td></tr> <tr><td>S</td><td>Special specification</td></tr> </table>	No symbol	No other options (standard)	BL	Battery-less motor (BL)	S	Special specification
No symbol	No option (standard)																																																						
Z	Z-Axis long stroke (Z)																																																						
No symbol	No option (standard)																																																						
B	Protective bellows for Z-Axis																																																						
C	Z-axis upper cap (C)																																																						
CRB	Cleanroom specification																																																						
WS	Z-axis (axis3) shaft for wire routing																																																						
IP	Dust-proof and splash-proof specification (IP65)																																																						
T	Ceiling-mount type																																																						
WB	Z-axis (axis 3) upper and lower bellows																																																						
No symbol	Cable length 3.5 m (standard)																																																						
L05	Cable length 5 m																																																						
L08	Cable length 8 m																																																						
L10	Cable length 10 m																																																						
L15	Cable length 15 m																																																						
L00R	Cable length 3.5 m (movable)																																																						
L05R	Cable length 5 m (movable)																																																						
L08R	Cable length 8 m (movable)																																																						
L10R	Cable length 10 m (movable)																																																						
L15R	Cable length 15 m (movable)																																																						
No symbol	Tool flange for end effector mounting (standard)																																																						
TF	Tool flange for end effector mounting																																																						
No symbol	No other options (standard)																																																						
BL	Battery-less motor (BL)																																																						
S	Special specification																																																						
		● No.5																																																					
		<table border="1"> <tr><td>No symbol</td><td>No special marking (standard)</td></tr> <tr><td>E</td><td>CE Marking</td></tr> <tr><td>K</td><td>KCs Marking</td></tr> </table>	No symbol	No special marking (standard)	E	CE Marking	K	KCs Marking																																															
No symbol	No special marking (standard)																																																						
E	CE Marking																																																						
K	KCs Marking																																																						

Option table

Type	No.	Symbol	THE400	THE600	THE800	THE1000
No option (standard)	1	No symbol	○ (160 mm)	○ (210 mm)	○ (420 mm)	○ (420 mm)
Z-Axis long stroke (Z)		Z	△	△	×	×
No option (standard)	2	No symbol	○	○	○	○
Protective bellows for Z-Axis		B	○	○	△	△
Z-axis upper cap		C	○	○	△	△
Cleanroom specification		CRB	△	△	△	△
Z-axis (axis3) shaft for wire routing		WS	○	○	△	△
Dust-proof and splash-proof specification(IP65)		IP	○	○	△	△
Ceiling-mount type		T	○	○	△	△
Z-axis (axis 3) upper and lower bellows	WB	△	△	△	△	
Cable length 3.5 m (standard)	3	No symbol	○	○	○	○
Cable length 5 m		L05	○	○	△	△
Cable length 8 m		L08	△	△	△	△
Cable length 10 m		L10	△	△	△	△
Cable length 15 m		L15	△	△	△	△
Cable length 3.5 m (movable)		L00R	△	△	△	△
Cable length 5 m (movable)		L05R	△	△	△	△
Cable length 8 m (movable)		L08R	△	△	△	△
Cable length 10 m (movable)		L10R	△	△	△	△
Cable length 15 m (movable)		L15R	△	△	△	△
Tool flange for end effector mounting (standard)		4	No symbol	○	○	○
Tool flange for end effector mounting	TF		○	○	○	○
No special marking (standard)	5	No symbol	○	○	○	○
CE Marking		E	○	△	△	△
KCs Marking		K	○*	△	△	△
No other options (standard)	6	No symbol	○	○	○	○
Battery-less motor (BL)		BL	○	×	×	×
Special specification		S	△	△	△	△

Ceiling-mount type (T)

Space can be saved by installing ceiling mounted robots above the work area. *Working envelope is different from standard specification. Please contact us for more details.

Change of cable length

Length of the cable between the robot and controller can be changed. Useful when the control panel is far away from the robot.

*Maximum length of cable between robot and controller depends on controller type. Please contact us for more details.

Tool flange for end effector mounting (TF)

Flange helps to attach a tool, such as a gripper, at the end of the ball screw.

*Please refer to dimensions of each robot for mounting method.

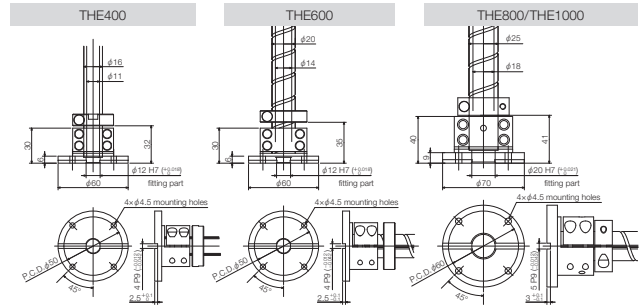

Battery-less motor (BL)

Motor does not require battery back-up. Periodic replacement of battery is not required.

○: Developed △: Please contact us for details ×: Not available

*Only for TSL3*** series controller. For TS5*** series controller, please contact us.

THL Series

Low cost

Impressive performance at affordable prices

Lightweight

Lightweight robot (minimum: 12 kg)
Easy installation in narrow spaces

Wide variety of arm lengths

Wide variety of arm lengths (300 mm to 1200 mm)
You can select the best robot for your application

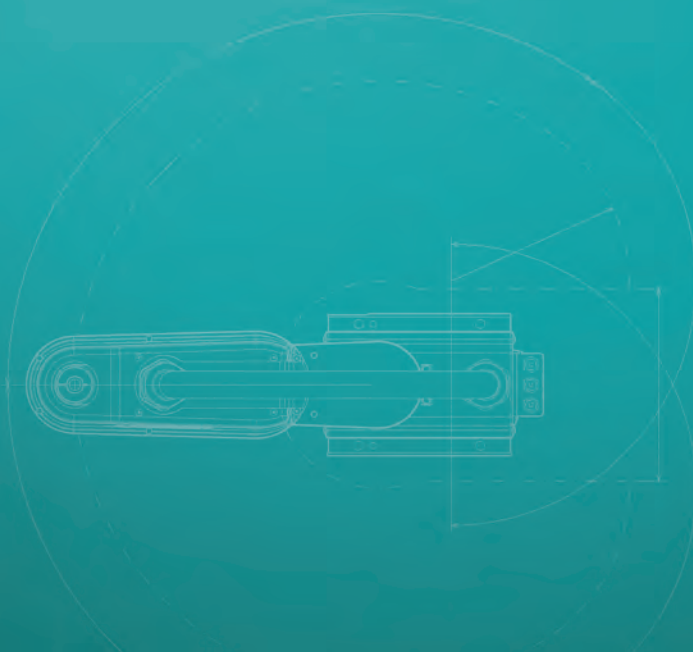

Order model code

THL 300 - Z - SC - K - S



Option B: Z With protective bellows, C: With cap, SC: Simple Cleanroom specification, IP6X: IP6X Dust-proof, T: Ceiling-mount type, LH: Low height design



THL300



THL400



THL500



THL600



THL700



THL800



THL900



THL1000



THL1200

Model	THL300	THL400	THL500
Arm length (1st Arm + 2nd Arm)	300 mm (125 mm+175 mm)	400 mm (225 mm+175 mm)	500 mm (200 mm+300 mm)
Maximum speed (Axis 1 and 2 composite)	5100 mm/s	6300 mm/s	6300 mm/s
Standard cycle time (with 2 kg load) ¹	0.48 sec	0.47 sec	0.45 sec
Maximum payload mass ²	5 kg (rated 2 kg)	5 kg (rated 2 kg)	10 kg (rated 2 kg)
Positioning repeatability ³	X-Y	±0.01 mm	±0.01 mm
	Axis Z (Axis 3)	±0.015 mm	±0.015 mm
	Axis C (Axis 4)	±0.007 deg	±0.007 deg
Mass	12 kg	13 kg	22 kg
Connectable controller	TSL3000, TSL3000E	TSL3000, TSL3000E	TSL3000, TSL3000E, TS5000-SS
Model	THL600	THL700	THL800
Arm length (1st Arm + 2nd Arm)	600 mm (300 mm+300 mm)	700 mm (400 mm+300 mm)	800 mm (350 mm+450 mm)
Maximum speed (Axis 1 and 2 composite)	7100 mm/s	7900 mm/s	4300 mm/s
Standard cycle time (with 2 kg load) ¹	0.45 sec	0.50 sec	0.47 sec
Maximum payload mass ²	10 kg (rated 2 kg)	10 kg (rated 2 kg)	10 kg (rated 2 kg)
Positioning repeatability ³	X-Y	±0.01 mm	±0.02 mm
	Axis Z (Axis 3)	±0.015 mm	±0.015 mm
	Axis C (Axis 4)	±0.007 deg	±0.007 deg
Mass	23 kg	24 kg	33 kg
Connectable controller	TSL3000, TSL3000E, TS5000-SS	TSL3000, TSL3000E, TS5000-SS	TSL3000, TSL3000E
Model	THL900	THL1000	THL1200
Arm length (1st Arm + 2nd Arm)	900 mm (450 mm+450 mm)	1,000 mm (550 mm+450 mm)	1,200 mm (750 mm+450 mm)
Maximum speed (Axis 1 and 2 composite)	4600 mm/s	5000 mm/s	5700 mm/s
Standard cycle time (with 2 kg load) ¹	0.48 sec	0.48 sec	0.58 sec
Maximum payload mass ²	10 kg (rated 2 kg)	10 kg (rated 2 kg)	10 kg (rated 2 kg)
Positioning repeatability ³	X-Y	±0.02 mm	±0.02 mm
	Axis Z (Axis 3)	±0.015 mm	±0.015 mm
	Axis C (Axis 4)	±0.007 deg	±0.007 deg
Mass	35 kg	37 kg	40 kg
Connectable controller	TSL3000, TSL3000E	TSL3000, TSL3000E	TSL3000, TSL3000E

¹: Continuous operation is not possible beyond the effective load ratio. Horizontal 300 mm, vertical 25 mm, round-trip with coarse positioning.
²: Acceleration/deceleration rates and maximum speed may be limited according to the motion pattern, load mass and amount of offset.
³: Positioning repeatability accuracy in one-direction movement, when the environmental temperature and robot temperature are constant. It is not the absolute positioning accuracy. The specification value may be exceeded depending on moving pattern, load mass and offset amount. Positioning repeatability for X-Y and C are for when Z-axis is at the uppermost position. Trajectory accuracy is not ensured.
⁴: Pneumatic joints for hand are provided on the base. Pipes are to be provided by the customers.

THL300



Model	THL300	
Arm length (1st Arm + 2nd Arm)	300 mm (125 mm+175 mm)	
Working envelope	Axis 1	±125 deg
	Axis 2	±145 deg
	Axis 3 (Axis Z)	0~160 mm
	Axis 4 (Axis C)	±360 deg
Maximum speed	Axis 1	660 deg/sec
	Axis 2	660 deg/sec
	Axis 3 (Axis Z)	1120 mm/sec
	Axis 4 (Axis C)	1500 deg/sec
	Composite (Axis 1 and 2 composite)	5100 mm/sec
Standard cycle time ^{*1}	0.48 sec (with 2 kg load)	
Maximum payload mass ^{*2}	5 kg (rated 2 kg)	
Allowable moment of inertia ^{*2}	0.05 kg·m ²	
Positioning repeatability ^{*3}	X-Y	±0.01 mm
	Axis Z (Axis 3)	±0.015 mm
	Axis C (Axis 4)	±0.007 deg
Hand wiring	8 inputs and 8 outputs	
Hand pneumatic joint ^{*4}	φ4 x 3 pcs	
Robot controller cable	3.5 m	
Power supply	0.7 kVA	
Mass	12 kg	
Connectable controller	TSL3000, TSL3000E	

For *1 to *4 please see page 15.

External View

* The air tubes are packed, which need to be installed by the user.

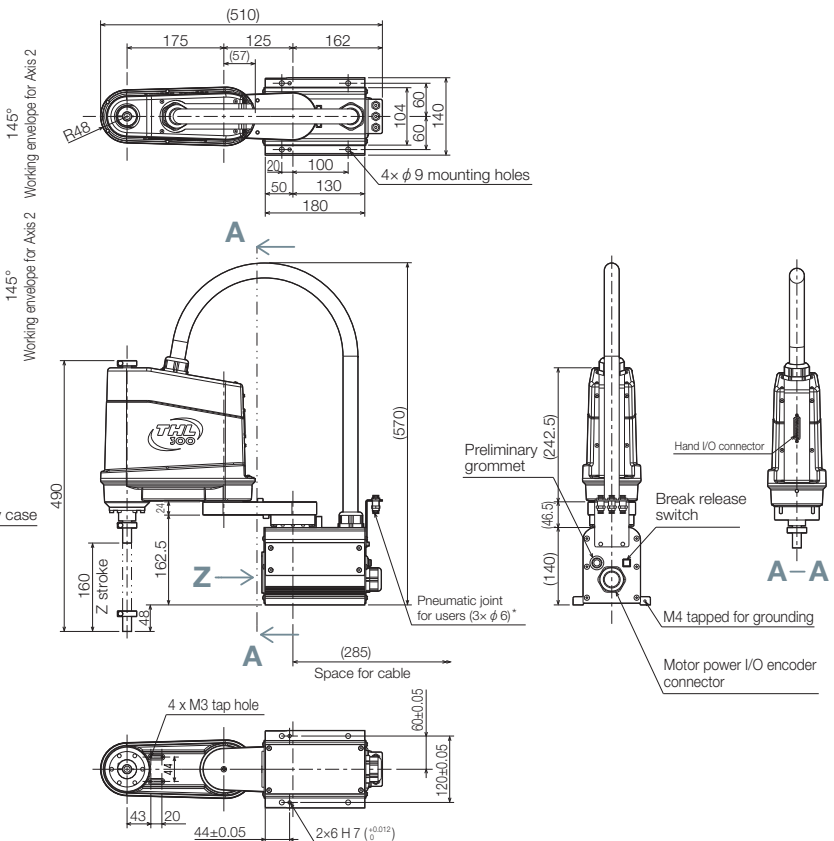
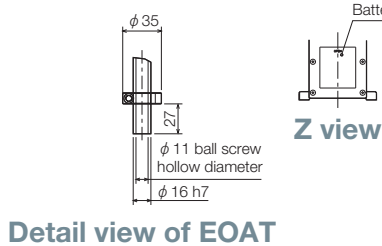
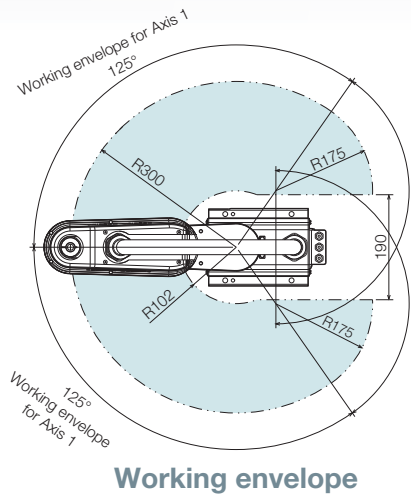

CAD Download URL <https://www.shibaura-machine.co.jp/en/product/robot/download.html>



THL500



Model	THL500	
Arm length (1st Arm + 2nd Arm)	500 mm (200 mm+300 mm)	
Working envelope	Axis 1	±125 deg
	Axis 2	±145 deg
	Axis 3 (Axis Z)	0~150 mm
	Axis 4 (Axis C)	±360 deg
Maximum speed	Axis 1	450 deg/sec
	Axis 2	450 deg/sec
	Axis 3 (Axis Z)	2000 mm/sec
	Axis 4 (Axis C)	1700 deg/sec
	Composite (Axis 1 and 2 composite)	6300 mm/sec
Standard cycle time ^{*1}	0.45 sec (with 2 kg load)	
Maximum payload mass ^{*2}	10 kg (rated 2 kg)	
Allowable moment of inertia ^{*2}	0.2 kg·m ²	
Positioning repeatability ^{*3}	X-Y	±0.01 mm
	Axis Z (Axis 3)	±0.015 mm
	Axis C (Axis 4)	±0.007 deg
Hand wiring	8 inputs and 8 outputs	
Hand pneumatic joint ^{*4}	φ6 x 3 pcs	
Robot controller cable	3.5 m	
Power supply	1.4 kVA	
Mass	22 kg	
Connectable controller	TSL3000, TSL3000E	

For *1 to *4 please see page 15.

External View

* The air tubes are packed, which need to be installed by the user.

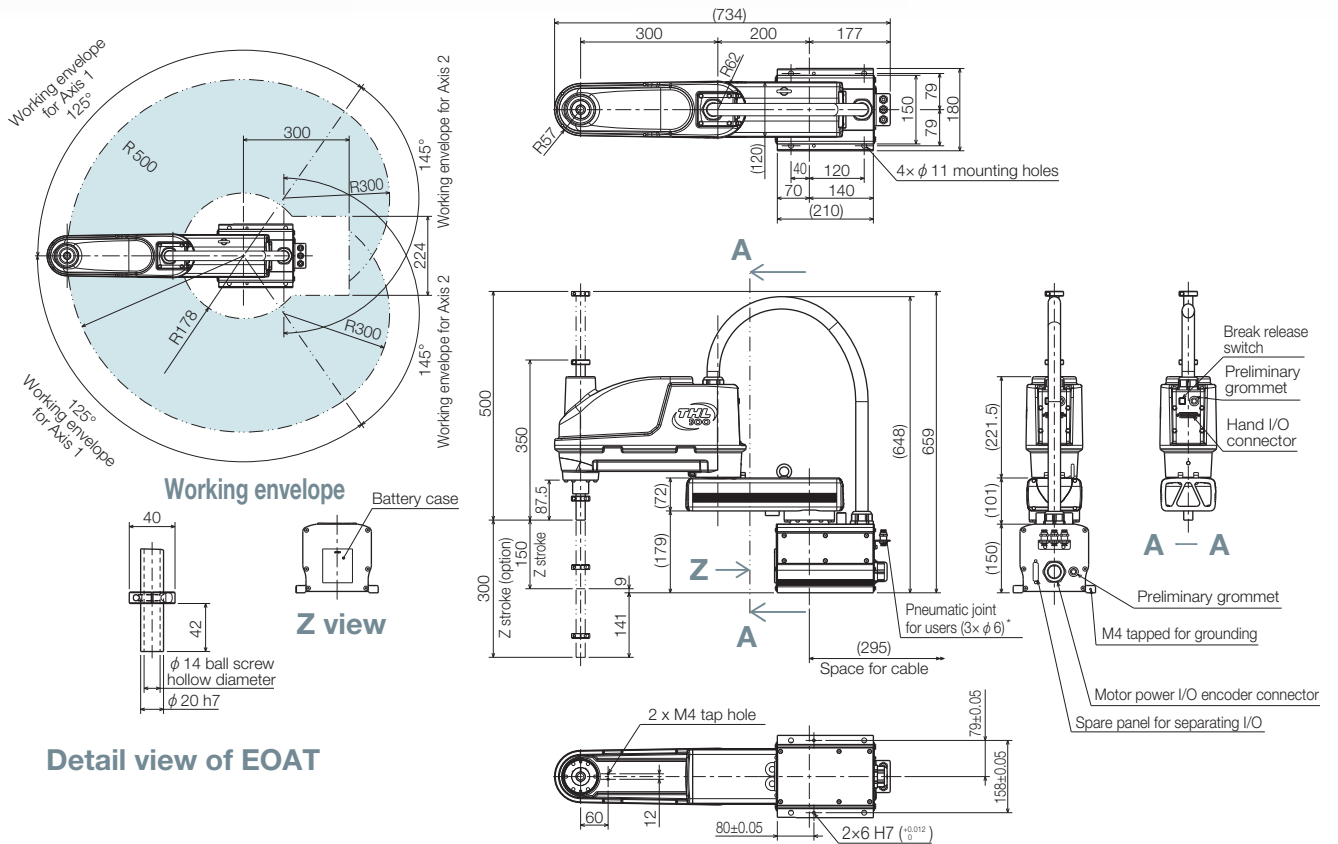

Detail view of EOAT

CAD Download URL <https://www.shibaura-machine.co.jp/en/product/robot/download.html>



THL700



Model	THL700	
Arm length (1st Arm + 2nd Arm)	700 mm (400 mm+300 mm)	
Working envelope	Axis 1	±125 deg
	Axis 2	±145 deg
	Axis 3 (Axis Z)	0~150 mm
	Axis 4 (Axis C)	±360 deg
Maximum speed	Axis 1	450 deg/sec
	Axis 2	450 deg/sec
	Axis 3 (Axis Z)	2000 mm/sec
	Axis 4 (Axis C)	1700 deg/sec
	Composite (Axis 1 and 2 composite)	7900 mm/sec
Standard cycle time ^{*1}	0.50 sec (with 2 kg load)	
Maximum payload mass ^{*2}	10 kg (rated 2 kg)	
Allowable moment of inertia ^{*2}	0.2 kg·m ²	
Positioning repeatability ^{*3}	X-Y	±0.01 mm
	Axis Z (Axis 3)	±0.015 mm
	Axis C (Axis 4)	±0.007 deg
Hand wiring	8 inputs and 8 outputs	
Hand pneumatic joint ^{*4}	φ6 x 3 pcs	
Robot controller cable	3.5 m	
Power supply	1.4 kVA	
Mass	24 kg	
Connectable controller	TSL3000, TSL3000E	

For *1 to *4 please see page 15.

External View

* The air tubes are packed, which need to be installed by the user.

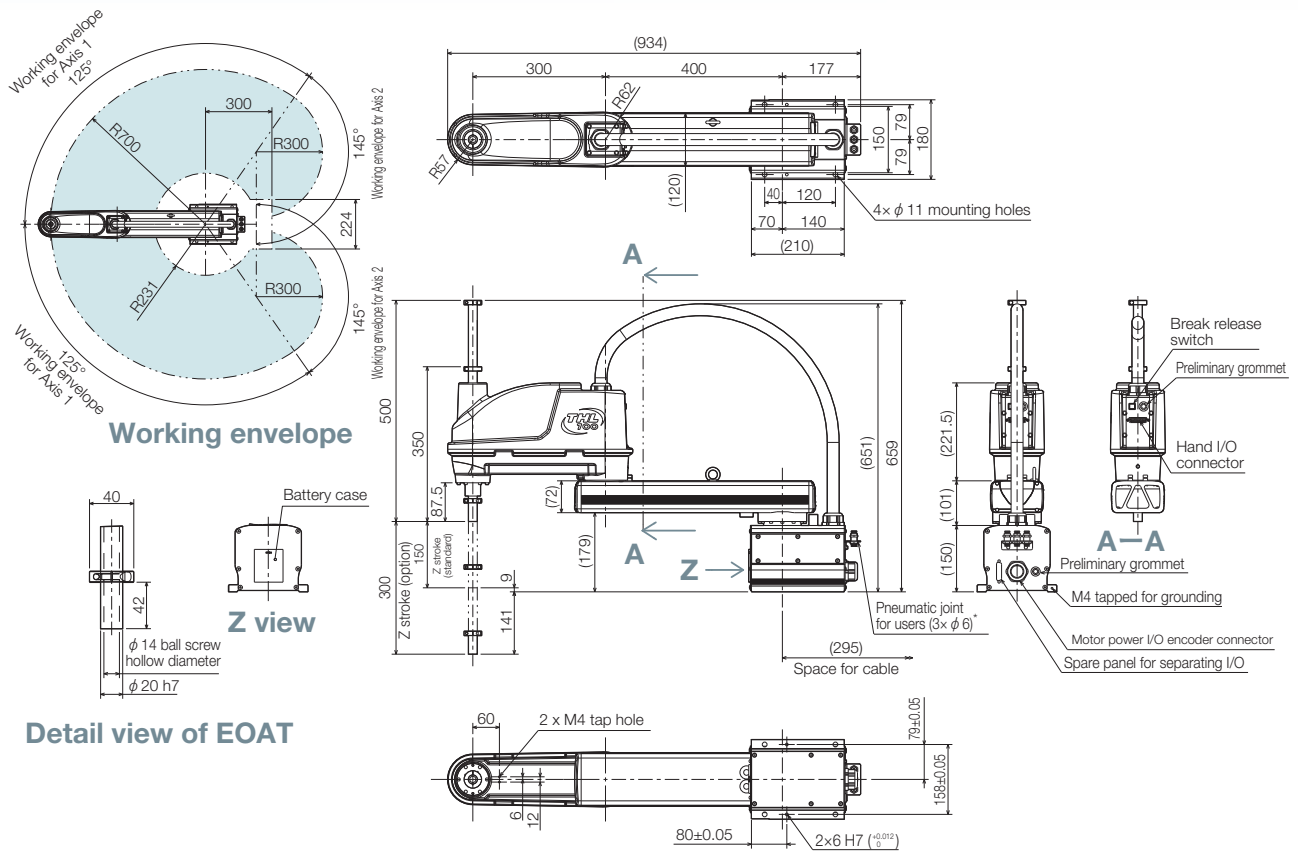

CAD Download URL <https://www.shibaura-machine.co.jp/en/product/robot/download.html>



THL800



Model	THL800	
Arm length (1st Arm + 2nd Arm)	800 mm (350 mm+450 mm)	
Working envelope	Axis 1	±125 deg
	Axis 2	±145 deg
	Axis 3 (Axis Z)	0~300 mm
	Axis 4 (Axis C)	±360 deg
Maximum speed	Axis 1	187.5 deg/sec
	Axis 2	217.5 deg/sec
	Axis 3 (Axis Z)	2000 mm/sec
	Axis 4 (Axis C)	1700 deg/sec
	Composite (Axis 1 and 2 composite)	4300 mm/sec
Standard cycle time ^{*1}	0.47 sec (with 2 kg load)	
Maximum payload mass ^{*2}	10 kg (rated 2 kg)	
Allowable moment of inertia ^{*2}	0.2 kg·m ²	
Positioning repeatability ^{*3}	X-Y	±0.02 mm
	Axis Z (Axis 3)	±0.015 mm
	Axis C (Axis 4)	±0.007 deg
Hand wiring	8 inputs and 8 outputs	
Hand pneumatic joint ^{*4}	φ6 x 3 pcs	
Robot controller cable	3.5 m	
Power supply	1.4 kVA	
Mass	33 kg	
Connectable controller	TSL3000, TSL3000E	

For *1 to *4 please see page 15.

External View

* The air tubes are packed, which need to be installed by the user.

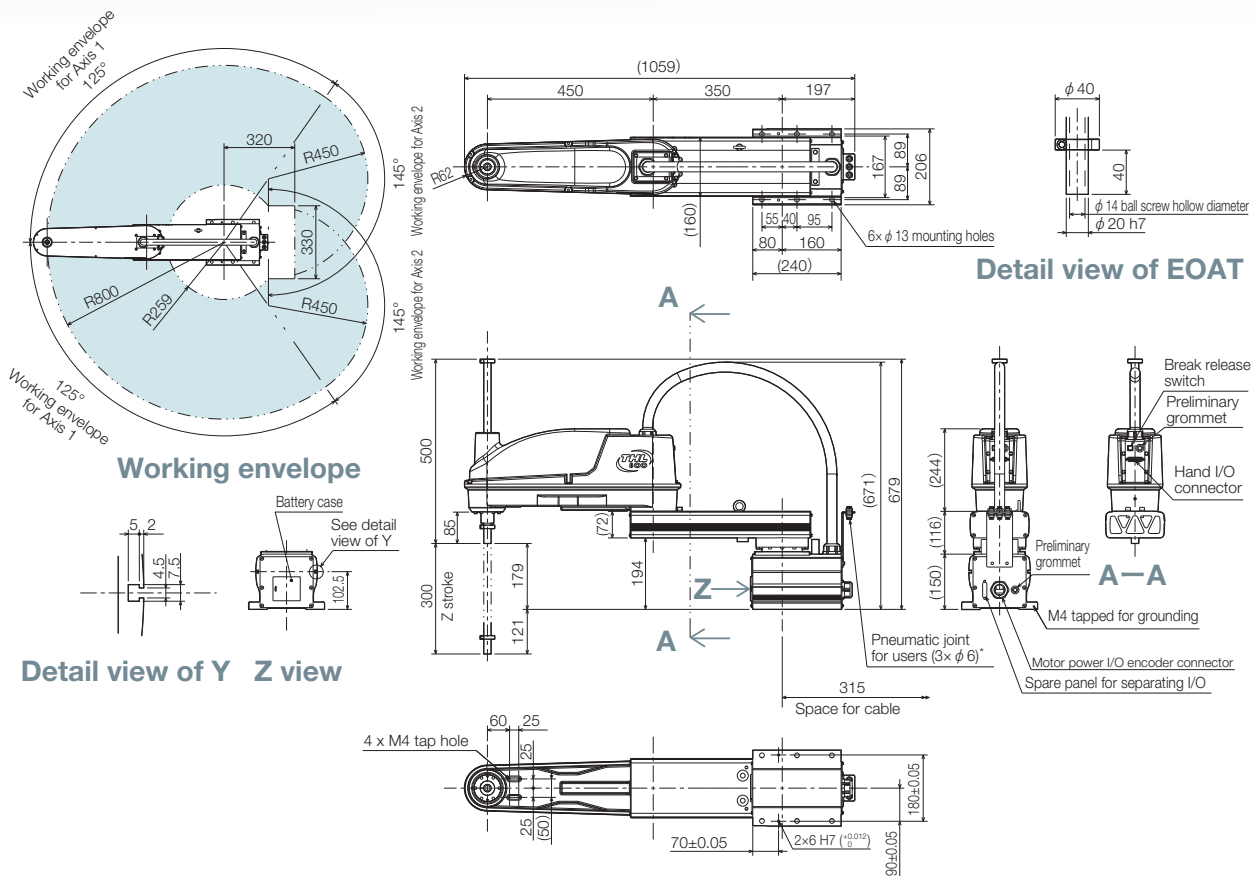

CAD Download URL <https://www.shibaura-machine.co.jp/en/product/robot/download.html>



THL900



Model	THL900	
Arm length (1st Arm + 2nd Arm)	900 mm (450 mm+450 mm)	
Working envelope	Axis 1	±125 deg
	Axis 2	±145 deg
	Axis 3 (Axis Z)	0~300 mm
	Axis 4 (Axis C)	±360 deg
Maximum speed	Axis 1	187.5 deg/sec
	Axis 2	217.5 deg/sec
	Axis 3 (Axis Z)	2000 mm/sec
	Axis 4 (Axis C)	1700 deg/sec
	Composite (Axis 1 and 2 composite)	4600 mm/sec
Standard cycle time ^{*1}	0.48 sec (with 2 kg load)	
Maximum payload mass ^{*2}	10 kg (rated 2 kg)	
Allowable moment of inertia ^{*2}	0.2 kg·m ²	
Positioning repeatability ^{*3}	X-Y	±0.02 mm
	Axis Z (Axis 3)	±0.015 mm
	Axis C (Axis 4)	±0.007 deg
Hand wiring	8 inputs and 8 outputs	
Hand pneumatic joint ^{*4}	φ6 x 3 pcs	
Robot controller cable	3.5 m	
Power supply	1.4 kVA	
Mass	35 kg	
Connectable controller	TSL3000, TSL3000E	

For *1 to *4 please see page 15.

External View

* The air tubes are packed, which need to be installed by the user.

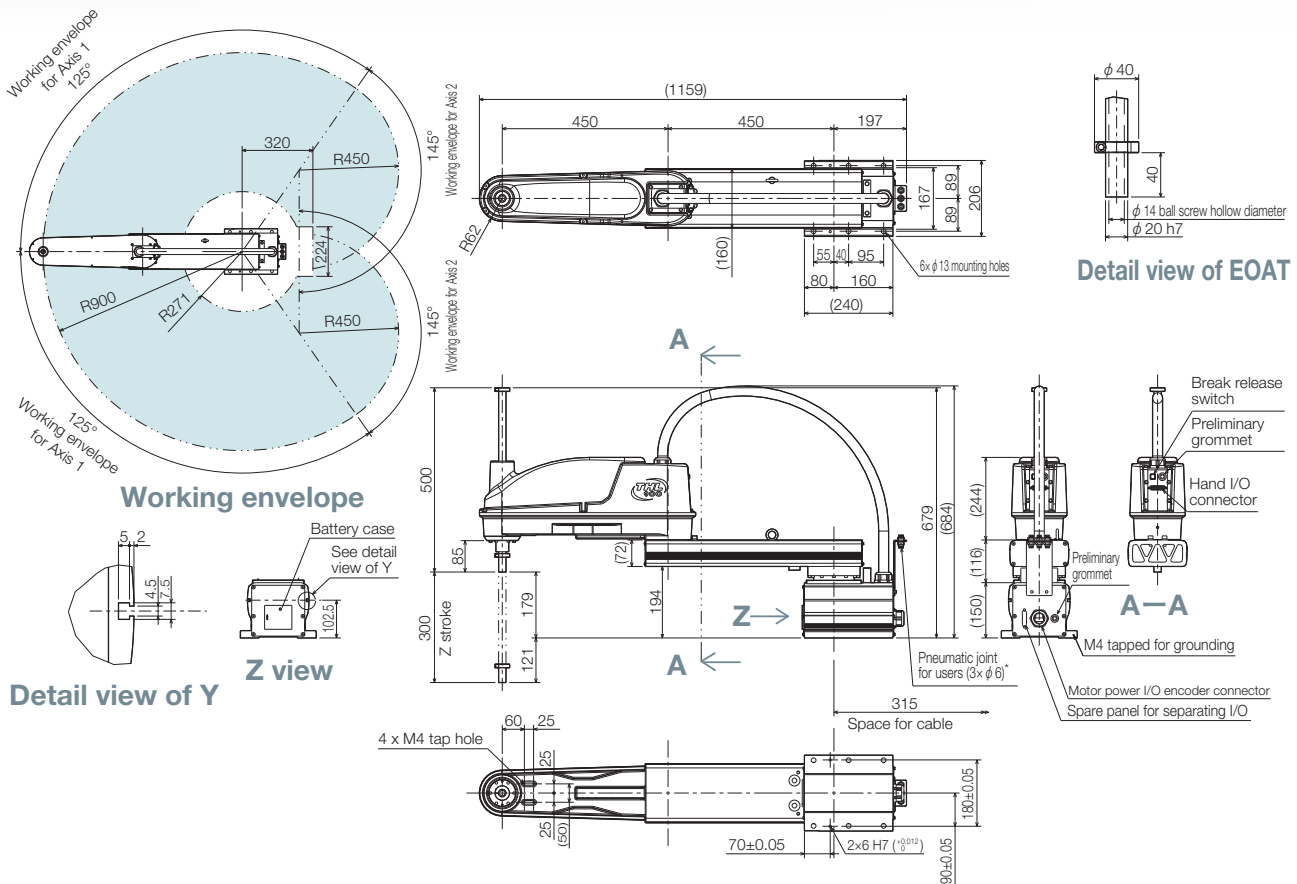

CAD Download URL <https://www.shibaura-machine.co.jp/en/product/robot/download.html>



THL1000



Model	THL1000	
Arm length (1st Arm + 2nd Arm)	1000 mm (550 mm+450 mm)	
Working envelope	Axis 1	±125 deg
	Axis 2	±145 deg
	Axis 3 (Axis Z)	0~300 mm
	Axis 4 (Axis C)	±360 deg
Maximum speed	Axis 1	187.5 deg/sec
	Axis 2	217.5 deg/sec
	Axis 3 (Axis Z)	2000 mm/sec
	Axis 4 (Axis C)	1700 deg/sec
	Composite (Axis 1 and 2 composite)	5000 mm/sec
Standard cycle time ^{*1}	0.48 sec (with 2 kg load)	
Maximum payload mass ^{*2}	10 kg (rated 2 kg)	
Allowable moment of inertia ^{*2}	0.2 kg·m ²	
Positioning repeatability ^{*3}	X-Y	±0.02 mm
	Axis Z (Axis 3)	±0.015 mm
	Axis C (Axis 4)	±0.007 deg
Hand wiring	8 inputs and 8 outputs	
Hand pneumatic joint ^{*4}	φ6 x 3 pcs	
Robot controller cable	3.5 m	
Power supply	1.4 kVA	
Mass	37 kg	
Connectable controller	TSL3000, TSL3000E	

For *1 to *4 please see page 15.

External View

* The air tubes are packed, which need to be installed by the user.

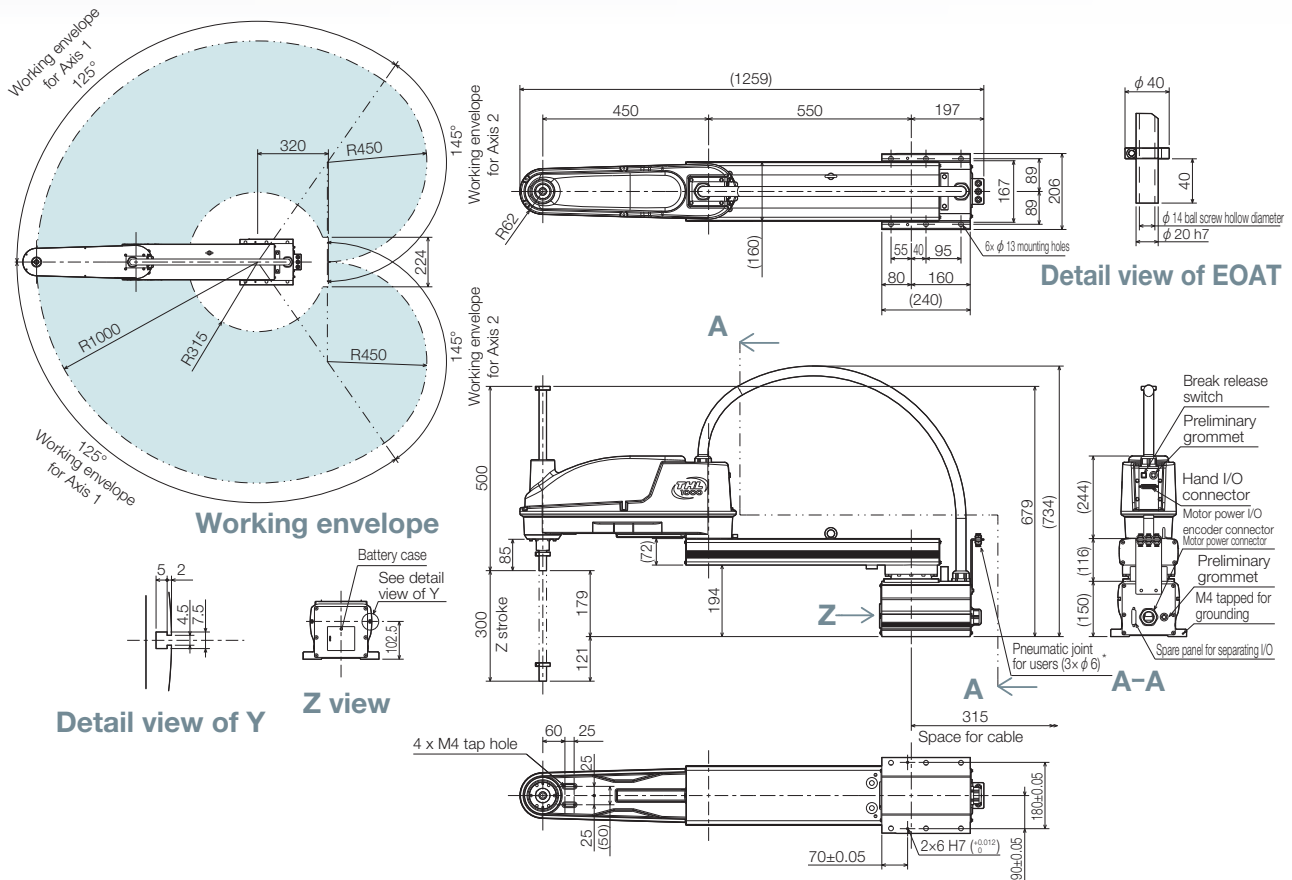

CAD Download URL <https://www.shibaura-machine.co.jp/en/product/robot/download.html>



THL1200



Model	THL1200	
Arm length (1st Arm + 2nd Arm)	1200 mm (750 mm+450 mm)	
Working envelope	Axis 1	±125 deg
	Axis 2	±155 deg
	Axis 3 (Axis Z)	0~300 mm
	Axis 4 (Axis C)	±360 deg
Maximum speed	Axis 1	187.5 deg/sec
	Axis 2	217.5 deg/sec
	Axis 3 (Axis Z)	2000 mm/sec
	Axis 4 (Axis C)	1700 deg/sec
	Composite (Axis 1 and 2 composite)	5700 mm/sec
Standard cycle time ^{*1}	0.58 sec (with 2 kg load)	
Maximum payload mass ^{*2}	10 kg (rated 2 kg)	
Allowable moment of inertia ^{*2}	0.2 kg·m ²	
Positioning repeatability ^{*3}	X-Y	±0.05 mm
	Axis Z(Axis 3)	±0.03 mm
	Axis C(Axis 4)	±0.014 deg
Hand wiring	8 inputs and 8 outputs	
Hand pneumatic joint ^{*4}	φ6 x 3 pcs	
Robot controller cable	3.5 m	
Power supply	1.4 kVA	
Mass	40 kg	
Connectable controller	TSL3000, TSL3000E	

For *1 to *4 please see page 15.

External View

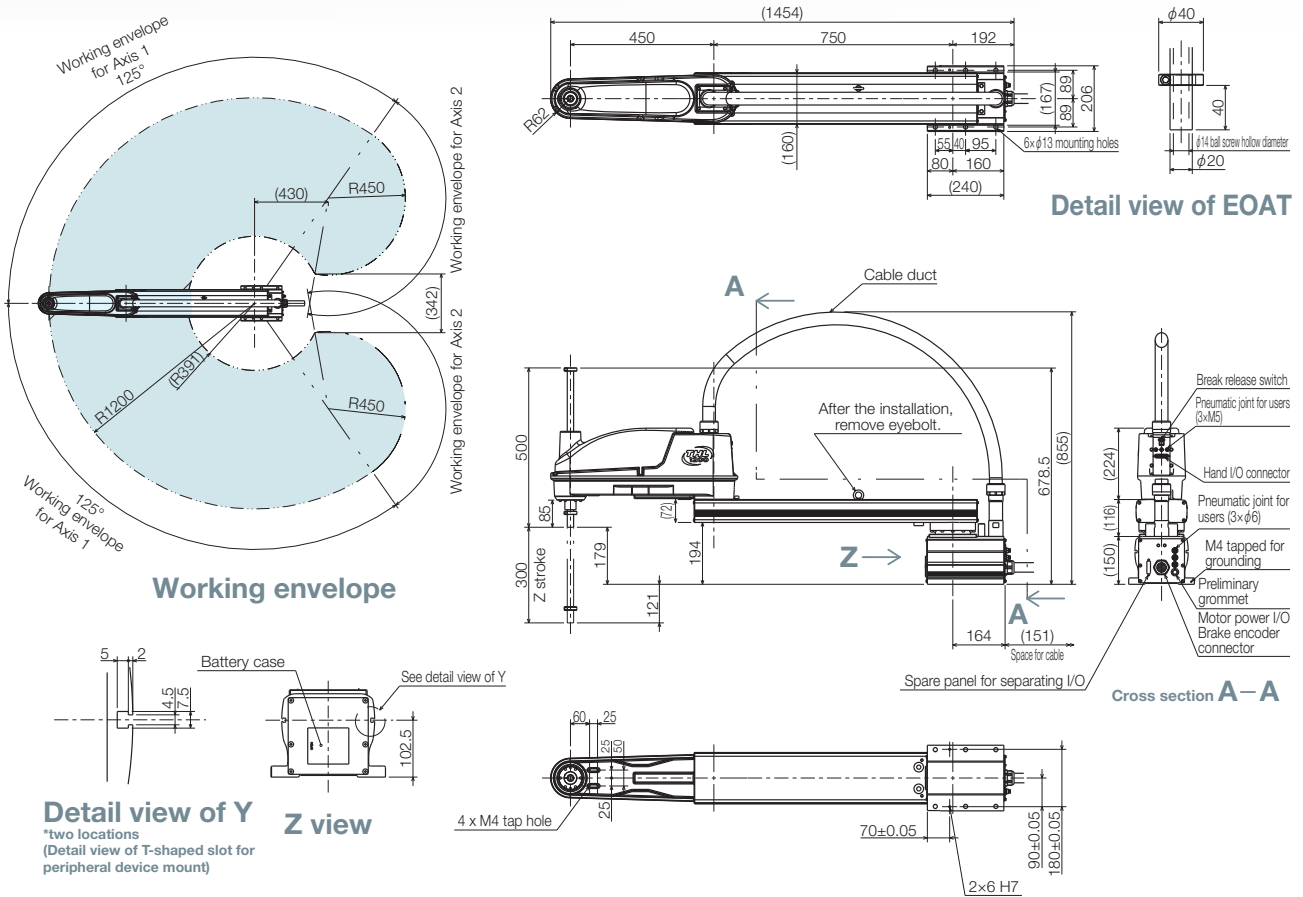

CAD Download URL <https://www.shibaura-machine.co.jp/en/product/robot/download.html>



Controller Teach Pendant

Small and lightweight

Small and lightweight controller (height 161 mm to 266 mm)
Contributes to the reduction in size of a control panel

Powerful software

Provides world-class programming support
User-friendly software

TC mini (simple PLC) function

Includes simple PLC function as standard
Customization possible for I/O allocation

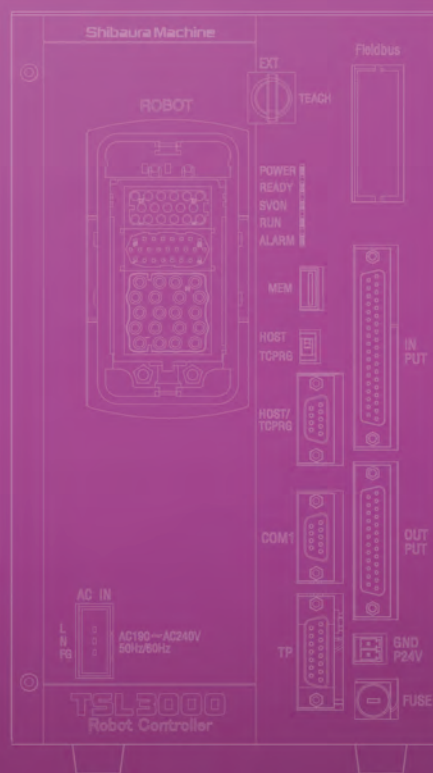

TS5000-SS TS5000-MS TS5000-EMS



TS5000-SS



TS5000-MS



TS5000-EMS

Order model code

EX. TS5000 - **SS** - **HR** - **IO** - **CC** - **CV**

Type of controller	Hand I/O	Extended I/O	Industrial field network	Conveyor tracking
SS Popular type of controller for SCARA Robot MS Popular type of controller for SCARA Robot EMS Controller with CE specification for SCARA robot	HR Hand I/O is built in the robot (8 inputs and 8 outputs) HC Hand I/O is built in the controller (8 inputs and 8 outputs)	No symbol Extended I/O not included IO Extended I/O included	No symbol No Fieldbus CC CC-Link DN DeviceNet PB PROFIBUS IP EtherNet/IP PN PROFINET CA EtherCAT	No symbol Conveyor tracking not included CV Conveyor tracking included

Improvement in synchronized control and tracking precision by better servo performances.

The synchronous control tracking system has been improved by improving the control processing cycle (the position control cycle is three times faster than the conventional machine).

This enables more sensitive control during robot's fast movements and improves its performance in such aspects as locus precision and vibration suppression. Acceleration auto adjustment function (SPURT function) - acceleration rate is increased when the load stress to the motor and reduction gear is low. This contributes to short cycle times.

Improved communication performances, and IoT ready fast data communication

Enhanced communication capabilities with Gigabit Ethernet. Real-time transmission of internal data is possible. Enhanced Ethernet communication functionalities for better usability. Simultaneous communication is possible through 8 general-purpose ports (IP 1 ~ 8) and dedicated ports for operation instructions, monitoring functions, and periodic communication, improving efficiency. Ready to meet the requirement for taking part in a "heavy edge" system, as better precision in AI vibration analysis and data collection for predictive and preventative maintenance.

Enhanced robot programming language

New compiler (processing system). Clearer and succinct SCOL program with new and improved commands. Character string type variables, string manipulation functions, new and improved commands for conditional branching, coordinate conversion functions, etc. all for clear and succinct programming.

The compact-size controller contributes to a smaller control panel.

The small and high-performance controller was realized by adopting a new CPU with high functionality. Additionally, all the connectors are on the front side. This reduces the size and installation area by approximately 2/3 compared to the existing model (TS3100). The smaller controller contributes to a smaller control panel. The fan-less design reduces maintenance.

Increase in user file capacity

File memory capacity is expanded to 12MB. By adding an SD card, it is expandable to maximum 32GB.

Others

Built-in PLC TC-Mini included. Can Modify the number of input and output signals.

Model	TS5000-SS	TS5000-MS	TS5000-EMS
Number of controlled axes	4 axis		
Program language	SCOL2 (Original language)		
Movement command	PTP (point to point), CP (Continuous Path: Linear,Circular), short-cut, arch motion		
Memory	Built-in Flash ROM, Capacity:12 Mbytes		
Auxiliary memory	SD card (SD and SDHC) Maximum capacity: 32 Gbytes		
Number of programs that can be stored	installed memory	Maximum:512 Usr files:502, System files:10	
	Auxiliary memory	Maximum:512 Usr files:512	
Maximum number of program lines	Per program, Data part:5,000 points, Program part: 5,000 lines		
I/O signals	General	8 inputs and 8 outputs	
	System	13 input signals: Program selection, start, stop, reset, etc. 9 output signals: Servo on ready to start, fault, etc.	
Communication port	Ethernet: 8 Ports		
Power supply*1	Main power supply	Single phase AC190 V to 240 V 50/60 Hz	
	Power supply for I/O signals	DC24 V (over 100 W)	
Outer dimensions	365 (W) × 161(H) × 325 (D) mm ^{*2}	365 (W) × 161(H) × 350 (D) mm ^{*2}	410 (W) × 161 (H) × 350 (D) mm ^{*2}
Mass	9 kg	11 kg	13 kg
Teach Pendant (optional)	TP5000, TP1000 ^{*3}		TP5000
Connectable robot	THE400, THL500, THL600, THL700	THE600, THE800, THE1000	THE400-E, THE600-E

*1 The power supply capacity is listed in the robot specification table.

*2 Height (H) includes rubber feet. Installation requires additional space for cabling, etc.

*3 Conversion cable required to connect TP1000.

Please see website for details <https://www.shibaura-machine.co.jp/en/product/robot/lineup/th/ts5000.html>



TSL3000

TSL3000E



TSL3000



TSL3000E

Please see website for details

<https://www.shibaura-machine.co.jp/en/product/robot/lineup/th/tsl3000.html>



Model	TSL3000	TSL3000E
Number of controlled axes	4 axis	
Program language	SCOL (Original language)	
Movement command	PTP (point to point), CP (Continuous Path: Linear,Circular), short-cut, arch motion	
Memory	0.5 MB	
Auxiliary memory	USB memory	
Number of installed programs that can be stored	Maximum: 256 Use files: 243 System files: 13	
Auxiliary memory	None	
Maximum number of program lines	Per program, Teaching points: 2000 points Program part: 3000 lines	
I/O signals	General	8 inputs and 8 outputs
	System	13 input signals: Program selection, start, stop, program reset, etc. 9 output signals: Servo on, emergency stop, fault, etc.
Communication port	RS-232C: 1 port (COM1) general	
Power supply ¹	Main power supply	Single phase AC190 V to 240 V 50/60 Hz
	Power supply for I/O signals	DC24 V (over 100 W)
Outer dimensions	150 (W) × 266 (H) × 304 (D) mm ²	320 (W) × 266 (H) × 304 (D) mm ²
Mass	7 kg	13 kg
Teach Pendant (optional)	Teach Pendant :TP1000	
Connectable robot	THL series THE400	

*1: Please see specification table for power capacity of each robot

*2: Height (H) includes the rubber legs.

Teach Pendant

TP5000



Model	TP5000
Display devices	7-Inch, wide TFT LCD
Input method	Touch-Sensitive Operator panel
Mass	800 g (except cable)
Outer dimensions	218 (W) × 173 (H) × 60 (D) mm
Cable length	5 m (standard), 10 m, 15 m (option)
Protection level	IP65
Connectable controller	TS5000-SS, TS5000-MS, TS5000-EMS

Improved operability

With 7-inch, widescreen color touch-sensitive panel, intuitive operation is realized.

In the larger display area, programs and position data can be checked in one glance.

With split-screen display, two sets of data can be displayed side by side, for example, the current position display and program monitor.

Multiple languages and switchable by setting.

Ease of handling and operation.

Easy to hold teach pendant for long periods of work

TP1000



Model	TP1000
Input method	Button
Mass	600 g (except cable)
Outer dimensions	133 (W) × 255 (H) × 48 (D) mm
Cable length	5 m
Connectable controller	TSL3000, TSL3000E, TS5000-SS ^{*3} , TS5000-MS ^{*3}

*1 The power supply capacity is listed in the robot specification table.

*2 Height (H) includes rubber feet. Installation requires additional space for cabling, etc.

*3 Conversion cable required to connect to TS5000-SS, TS5000-MS.

Built-in PLC TCmini

Each controller has a built-in PLC (Tcmini) Input and output signals can be handled by ladder-style programming logic, independent from the robot motion.

*TC-WORX is required for editing the ladder program.

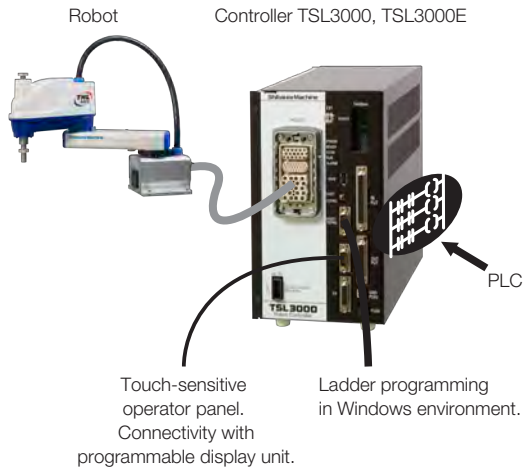

Vision + Conveyor Synchronization

- A large number and variety of types of work pieces on a conveyor can be sorted and put into boxes by multiple robots in coordination.
- Damage and breakage of work pieces is avoided by synchronization with the conveyor.
- Programming is made easy with special, dedicated commands to achieve efficient work-piece handling, with functionalities such as identification and duplicate data avoidance.

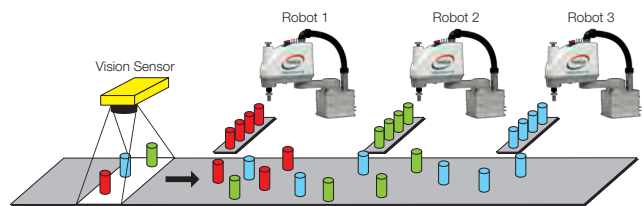

Industrial networks

The controllers supports CC-Link, DeviceNet, PROFIBUS, EtherNet/IP, EtherCAT, and PROFINET. You can output the start signal from the sequencer to the controller, and monitor the status of the controller with the sequencer.

CE Marking

KCs Marking

Applicable to each marking

Additional axis

An additional axis can be added for usage such as moving the robot on a traverse axis.

Extended I/O Unit

The number of I/O signals can be increased with the addition of the extended I/O module. Possible to add 56 input signals and 40 output signals.

Option table

	TS5000-SS	TS5000-MS	TS5000-EMS	TSL3000	TSL3000E
Built-in PLC TCmini	1 k word 2 ms	1 k word 2 ms	1 k word 2 ms	1 k word 5 ms	1 k word 5 ms
Industrial network ¹	CC-Link	○	○	○	○
	DeviceNet	○	○	○	○
	PROFIBUS	○	○	○	○
	EtherNet/IP	○	○	○	○
	EtherCAT	○	○	○	○
	PROFINET	○	○	○	○
Vision + Conveyor Synchronization	○	○	○	×	○
CE Marking	×	×	○	×	×
KCs Marking	×	×	×	○ ^{*2}	○ ^{*2}
Additional axis	×	×	×	○	○
Extended I/O Unit	21 inputs/17 outputs	21 inputs/17 outputs	21 inputs/17 outputs	56 inputs/40 outputs	56 inputs/40 outputs
Connectable robot	THL500, THL600, THL700, THE400	THE600, THE800, THE1000	THE400-E, THE600-E	THL series	THL series

¹ : Ethernet is registered trademark of XEROX Corp. from the U.S.

CC-Link is registered trademark of CC-Link society

Device Net and Ethernet I/P is registered trademark of ODVA.

PROFIBUS and PROFINET is registered trademark of PROFIBUS User Organization.

Ether CAT is registered trademark and patent technology of Beckoff Automation GmbH from Germany.

²: Not applicable to THL1200

Robot Programming Assist Tool



Easy Operation

Easy-to-understand, intuitive screen design, ribbon interface, window-dock function for customizable operator panels

Beginners will find it easy to understand and can quickly master robot programming skills. For experienced robot users, TSAssist helps them make robot programs efficiently.

- Easy-to-understand, intuitive screen design
- Ribbon interface
- Customized operation panels by window-dock function

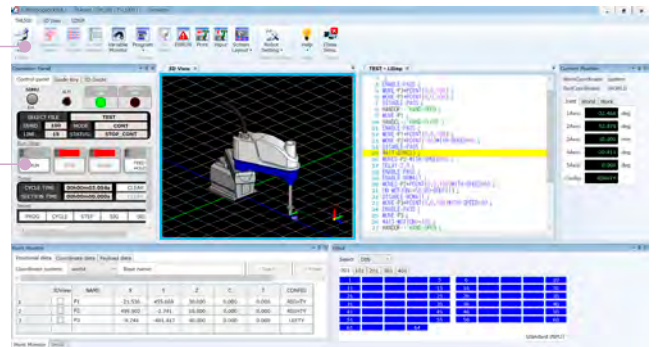

High Performance 3D Simulation

Interference check, Locus display, timer (cycle time measurement), placing simple work pieces and model shapes, loading 3D CAD data, saving 3D simulations to a video file and multi-angle view

These functions enable the accurate and high quality estimation of robot-automation processes. From simple outline simulation to detailed simulation closer to actual machine implementation, TSAssist helps with all phases of the robot automation system life cycle, from initial "sketch," planning, proposal, designing and installation, to the improvement and repurposing of existing facilities.

* ".stl" files of 3D CAD data can add to TSAssist directly. The conversion software "Virfit Agent" is required to add the ".stp" files of 3D CAD data.

* USB license key (sold separately) is required to use the high performance 3D simulation.

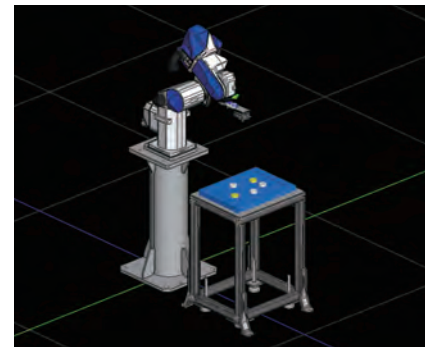

▪ Interference check

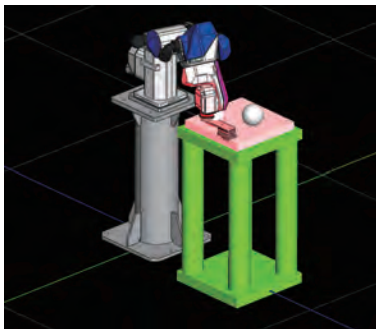

▪ Locus display

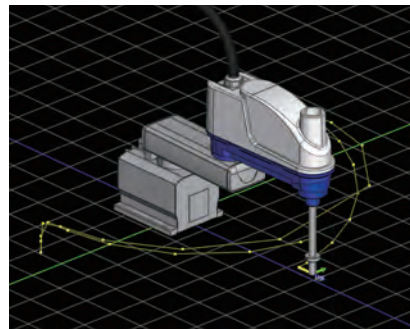

▪ Placing simple work pieces

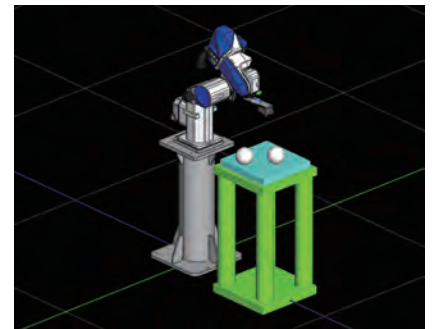

▪ Loading 3D CAD data

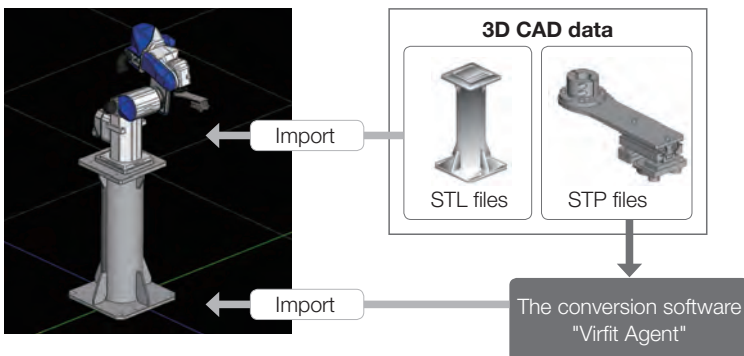

▪ Multi-angle view

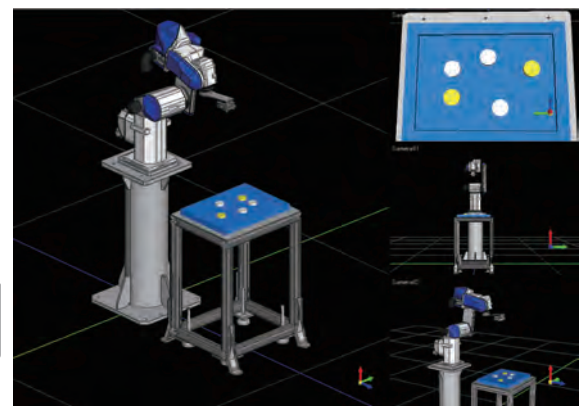

▪ Timer (cycle time measurement)

▪ Saving 3D simulation to a video file

Highly Functional Program Editor

Robot language input support (keyword suggestions), outline display and split display.

Point data (taught position information) editor with, sort, search and filter functions. In 3D editor mode, the robot can be guided by mouse dragging and by clicking on the object model surface. No complex position calculation is necessary. With these functions, programming can be done efficiently with minimum mistakes.

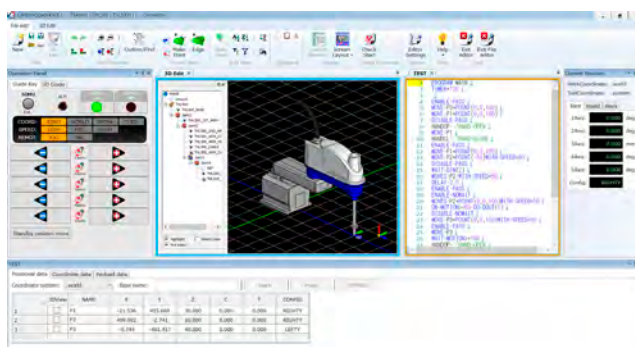

■ Robot language input support (keyword suggestions)

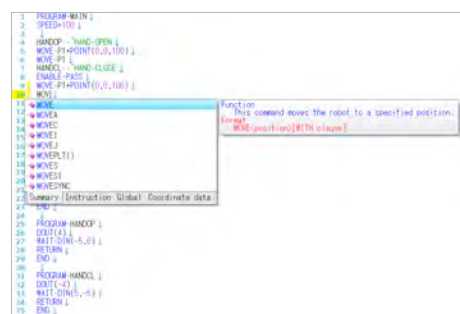

■ Outline display



■ Split display

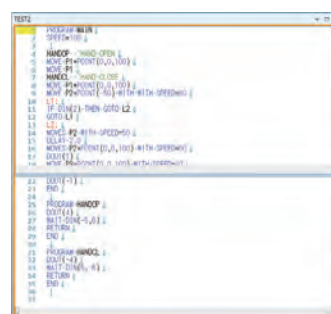

■ Point data editor's sort, search and filter functions

■ 3D editor mode enables robot guidance and teaching by mouse

Operating environment

OS	Windows7 / 8.1 / 10 (32/64bit)
CPU	Intel Core I series or newer than Intel Core2 Quad
Memory	More than 2 GB recommended
Monitor	Screen resolution 1024×768 (WXGA) or higher *1366×768 (FEXGA) is recommended
HDD	More than 1 GB free hard drive space
Graphics (display)	NVIDIA GeForce series, Quadro series, Intel HD Graphics 4000 or newer recommended DirectX 9.0c ready More than 64 MB graphics memory recommended Direct3D Acceleration enable
Mouse	Use Wheel Mouse for operation
USB	Use 1Port (USB2.0 for USB license key)
DVD-ROM	Use DVD-ROM drive to install this software
I/F	LAN-Port or COM-Port for connect to Controller

TC-WORX

For programming the simple PLC

1. Ladder-style logic programming for the simple PLC.
2. In addition to program creation, online monitoring of ladder program and I/O status to help reduce development and debugging time.
3. Extensive functions, such as address map display, comment display and search, are provided.

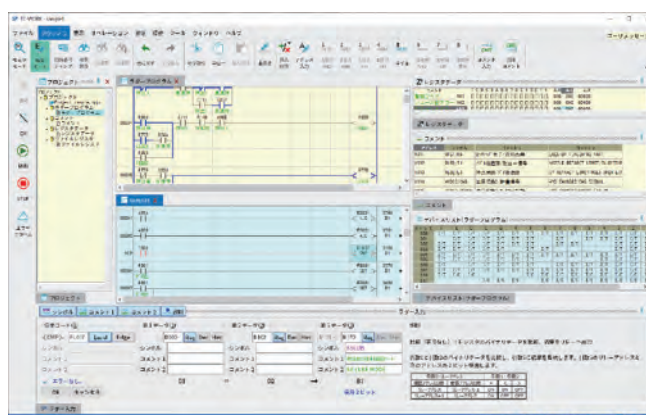

Robot selection guidelines

In order to select a robot model please consider the following factors:

1 Mass and center of gravity-offset values of the work piece and end of arm effector combined



2 Environmental requirements of the installation site

Environment types: general, cleanroom, dust and splash proof.



3 Area coverage requirements and installation configurations

Please review the external dimension drawing (CAD file) of each model for the working envelope (area coverage).
For example: Standard floor-mounted configuration or optional ceiling-mount configuration.
For example: For a SCARA robot, whether vertical (Z) long-stroke option is required.

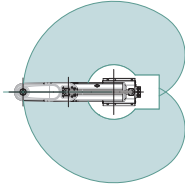

An example SCARA robot working envelope



4 The robot motion patterns and the time requirement (cycle time) review



5 Cable length requirements (the distance between the robot and the controller)

Please refer to the specification table of each model for standard cable lengths.
Optional cable lengths are available. Optional movable cable is available.

6 Controller option requirements

Please refer to the specification table of each model for available controller options.
For example: Whether optional field network connectivity is required.



7 Teach Pendant (optional)

Please select according to the robot type.

For SCARA robots



TP1000



TP5000



8 PC software

Please select according to the robot type.

For SCARA robots

TSAssist	TC-WORX
Programming assistance software	Programming assistance software for TCmini (simple PLC)

* This document presents an overview of our robot product lineup. For full details, such as specification data and external dimension CAD files, please refer to the brochure for each model and our website. Please contact our sales representatives with any questions you may have.

SHIBAURA MACHINE CO., LTD.

Control Systems Sales Department, Control Systems Company
840 Shimotogari, Nagaizumi-cho, Sunto-gun Shizuoka-ken 411-8730, Japan
TEL: 81-(0)55-926-5032 FAX: 81-(0)55-925-6527

TM Robotics (Europe) Ltd
Unit 2, Bridge Gate Centre Martinfield Welwyn
Garden City Hertfordshire AL7 1JG UK
Tel No: +44 (0) 1707 290 370
Fax No: +44 (0) 1707 376 662
www.tmrobotics.co.uk

TM Robotics (Americas) Inc
755 Greenleaf Ave - Elk Grove Village, IL - 60007 - USA
Tel No: +1-847-709-7308
Email: www.tmrobotics.com

www.shibaura-machine.co.jp/



* Please note that the contents of this document may change without notice