

For TVM Series

TSL3200E

CE compliant



TSL3200E

Controller Specifications

Model	TSL3200E
Number of Control axes	Maximum 6 axes
Motion Modes	PTP,CP(Continuous Path; Linear, Circular), Short-cut
Storage Capacity	Approx. Total: 128,000 point data + 25,600 steps 1 program: 2,000point data + 3,000 steps
Number of Registrable Programs	Maximum 256
External Memory	USB memory
Programming Language	SCOL language (similar to Basic)
Teaching Pendant (Optional)	TP3000, TP1000-6ax, (Programs can also be written on PC)
I/O Signals	8 inputs / 8 outputs (Plus or minus common selectable)
Hand Control Signals	Maximum 8 inputs / 8 outputs
PLC function	Built-in PLC
Communication Ports	RS232C : 2 Ports, Ethernet : 1 Port, USB 1 Port (for external memory)
Functions	Interruptive functions, self-diagnosis, I/O Control and Communications during motion, Coordinate Calculations, Built-in PLC, Conveyor Synchronization (optional), etc.
Power Supply	Single phase AC 190 to 240V, 50/60 Hz
Outer Dimensions and Mass	470(W) × 290(H) × 304(D) mm, 21kg (including rubber feet)
PC software for Programming support (Optional)	TSAssist : Program editor, Teaching, Remote Operation, Simulation, etc.
Options	Additional Axes (max. 2 axes), I/O Extension, I/O Cables, Field Network (PROFIBUS, DeviceNet, CC-Link, EtherNet/IP, EtherCAT, PROFINET) Conformance to various industrial Standards.

*: Ethernet is a registered trademark of XEROX Corp. in the U.S.A. CC-Link is a registered trademark of CC-Link Partner Association. DeviceNet and EtherNet/IP are registered trademarks of ODVA. Profibus and PROFINET are registered trademark of PROFIBUS User Organization. EtherCAT® is registered trademark and patented technology, licensed by Beckhoff Automation GmbH, Germany.

TSL3200E

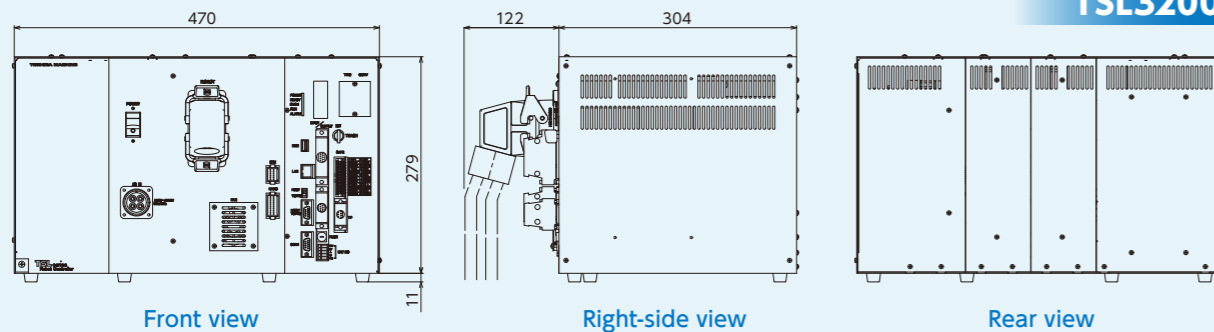

EASY INTRODUCTION OF BIN-PICKING AUTOMATION SYSTEM

Teach pendant **Optional**

TP1000-6ax

Standard Teach pendant



TP3000

Teach pendant equipped with graphic operation keys



TOSHIBA MACHINE CO., LTD. HEAD OFFICE

Control Systems Sales Department, Control Systems Division
2068-3, Ooka, Numazu-shi, Shizuoka-ken 410-8510, Japan
TEL:[81]-055-926-5032 FAX:[81]-055-925-6527

TM ROBOTICS (AMERICAS) INC.

755 Greenleaf Avenue, Elk Grove Village, IL 60007, U.S.A.
TEL:[1]-847-709-7308 Mail:info@tmrobotics.com

TM ROBOTICS [EUROPE] LTD.

Unit 2, Bridge Gate Centre, Martinfield, Welwyn Garden City, Herts AL7 1JG, UK
TEL:[44]-01707-290370 Mail:sales@tmrobotics.co.uk

URL : <http://www.toshiba-machine.co.jp/jp/product/robot/index.html>
<http://www.tmrobotics.co.uk>
<http://tmrobotics.com>

■The Contents in this document are subject to change without prior notice.

- System Robot
- Servo System
- Programmable Controller



Before operating the industrial robot, read through and completely understand the instruction man



VERTICAL ARTICULATED ROBOT

TVM Series



TVM900



TVM1200



TVM1500



For TVM Series Controller

TSL3200E

